



Operating and Installation Instructions

CAUTION!

This product is to be installed only by persons knowledgeable in the repair and modification of vehicle fuel systems and general vehicle systems modification. Only a qualified technician or mechanic who is aware of applicable safety procedures should perform the installation of this product.

GASOLINE AND OTHER FUELS ARE FLAMMABLE AND CAN BE EXPLOSIVE!

Perform the installation in a well ventilated location only to minimize the build up of fuel vapors. **NO** open flames, smoking or other sources of ignition are to be present during installation, to prevent fire or explosion that can cause serious injury or death. Grinding, cutting, and drilling must be performed with care to prevent ignition. Draining and removal of all fuel and ventilation of vapors in vehicle and fuel system is recommended when performing such procedures. Proper eye and personal protection is required at all times during installation.

DO NOT smoke, have lighted substances, or carry open flame of any type around when working near the vehicle during installation of this kit, including road tests and final inspections.

DO NOT have personal electronic devices near the vehicle during installation, to prevent possibility of igniting fuel.

WARNING!

The Vehicle's fuel system may be under pressure! **DO NOT** loosen any fuel connections until relieving all fuel system pressure. Consult an applicable service manual for instructions to relieve fuel system pressure safely.

Application:

This Installation Kit is intended to be used with Fuelab® brand of Power Modules, including Models 90902, 91901, 92902, 92911, 92912 and 92913. Power Modules are Fuel Pumps that load into a flange that allow the pump to reside in the fuel tank or fuel cell. Use of this kit requires machining or fabrication of the vehicle's Fuel Tank or Fuel Cell. Machining can include the use of a drill with a hole saw. If this kit is incorrect, please contact your Fuelab® distributor immediately for replacement or selection of an appropriate Installation Kit.

Product Contents:

Verify the contents of this box, against the list of components and the diagram on next sheet (Sheet 2) to ensure that nothing is missing. When laying out the components, keep the parts close to each other as displayed in diagram (for convenience). Also note that o-ring (Item 12) may be pre-installed in Inlet Adapter Fitting (item 9). Contact your Fuelab® distributor immediately for replacement, if any items are missing.

FOLLOW ALL INSTRUCTIONS HEREIN AS WELL AS INSTRUCTIONS INCLUDED WITH THE FUEL PUMP (POWER MODULE, SEE APPLICATION SECTION). BOTH SETS OF INSTRUCTIONS CONTAIN IMPORTANT INFORMATION!

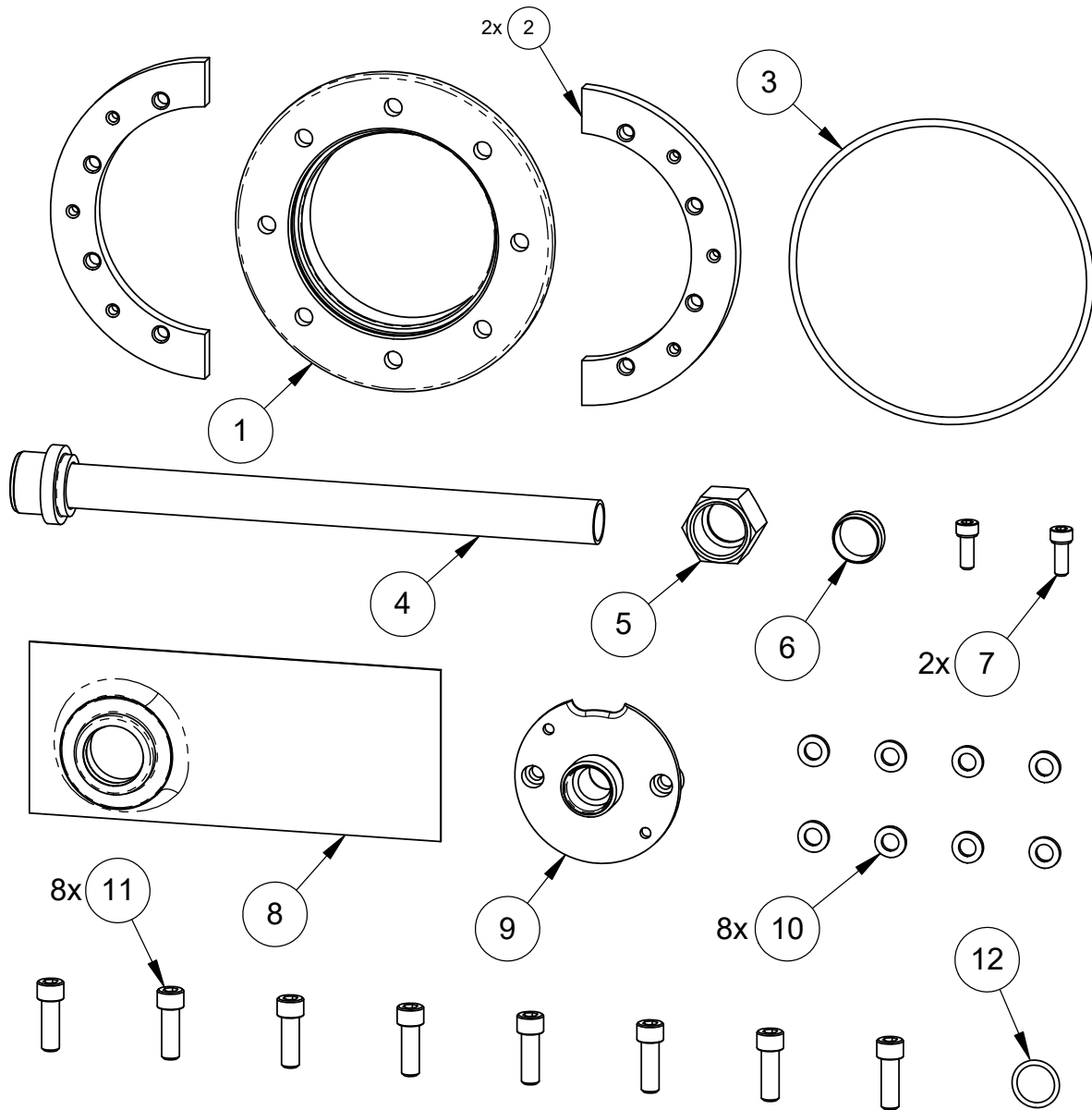

ITEM	Description	Qty
1	Flange	1
2	Tank Ring	2
3	O-ring, for Flange (Size -156)	1
4	Pick Up Tube Assembly (5/8" Line)	1
5	Compression Nut (for 5/8" Line)	1
6	Compression Ferrule (for 5/8" Line)	1
7	Cap Screw, #10-32 x 1/2" Long	2
8	Inlet Straining Filter (Fuelab Model 83801)	1
9	Inlet Fitting Adapter (for compression nut)	1
10	Nylon Washer	8
11	Cap Screw. 1/4"-20 x 3/4"	8
12	O-ring, Inlet Adapter Seal (Size -015)	1

Step 1: Open and sort the components, included in the Power Module (sold separately, reference Application Section herein).

Step 2: Follow all instructions included with the Power Module, including planning notes regarding plumbing and electrical requirements.

Step 3: Refer to the requirements shown in figures on this sheet and the next sheet regarding tank requirements. These include:

- Flat top with an accessible area at 4-5/8" diameter. This area **MUST HAVE** a good surface finish to seal the flange (Item 1) to the tank using the provided O-ring (Item 3). This Flat Area can be at an angle or even side of the fuel tank if required. **DO NOT INSTALL ON THE BOTTOM OF THE TANK!!**
- Minimum Depth (reference figures) is 9.100 inches (225mm) for Models 90902, 91901 and 92902. Minimum Depth is 7.875 inches (200mm) for Models 92911, 92912 and 92913.
- Minimum Length (reference figures) is 7.75 inches (195mm)
- Minimum Width (reference figures) is 5.5 inches (140mm)

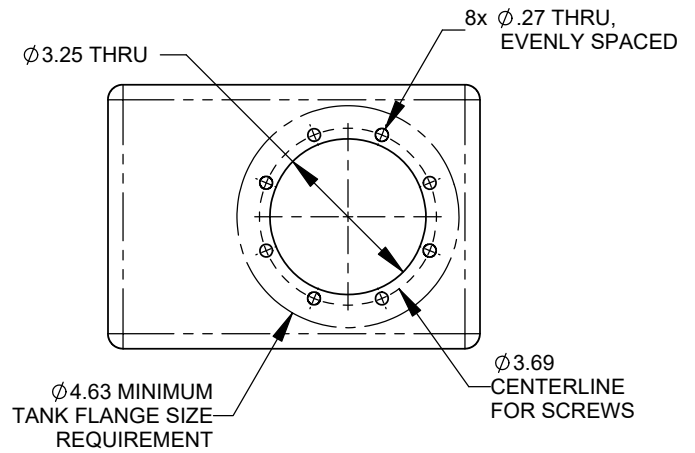

TANK FABRICATION REQUIREMENT SHOWN ABOVE

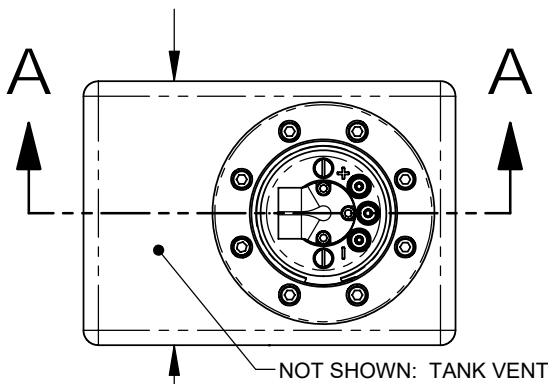

5.50 RECOMMENDED MINIMUM TANK WIDTH

FUELAB POWER MODULE SHOWN INSTALLED. (SOLD SEPARATELY)

7.75 RECOMMENDED MINIMUM TANK LENGTH (DUE TO FILTER LENGTH)

**TANK MUST BE VENTED!
DO NOT ALLOW A VACUUM TO FORM
INSIDE TANK!**

9.10 MINIMUM TANK DEPTH

7.88 MINIMUM TANK DEPTH

**SECTION A-A
MINIMUM INSTALLATION HEIGHT
SHOWN ABOVE
MODELS 90902, 91901 AND 92901 ONLY**

**MINIMUM INSTALLATION HEIGHT
SHOWN ABOVE
MODELS 92911, 92912 AND 92913 ONLY**

Other requirements include being vented to atmosphere. While it is possible to have the Power Module installed inside a reservoir or surge tank, the maximum pressure allowable is 20 PSIG. A vacuum **CANNOT** be allowed to form inside the tank in **ANY** instance! Fuel Pump failure will result, if a vacuum is formed inside the tank.

See the diagram below, showing the maximum depth allowed for application. Two auxiliary outlet ports (per 1/8"-NPT) are available on the outlet cap of the Power Module as shown (Models 90902, 91901 and 92902 ONLY). These ports have plugs installed, and can be used for alternate purposes. One such purpose is to be used for Jet Pump(s). Jet Pumps (such as Fuelab® 21901) are sometimes referred to as Eductors. These devices use pressurized fuel to allow pumping action, to allow fuel to be drawn from another source. These are commonly used in saddle tank designs, to allow fuel to be drawn from an area of the tank that is isolated from the primary sump area of the fuel tank. **SPECIAL NOTE: ANY** item connected to these auxiliary output ports prevent "cartridge loading" through the Flange of this kit thus requiring installation of the Power Module via alternate access. Cartridge loading is referred to the installation and removal of the Power Module through the Flange portion of this kit (Reference *Step 18* herein).

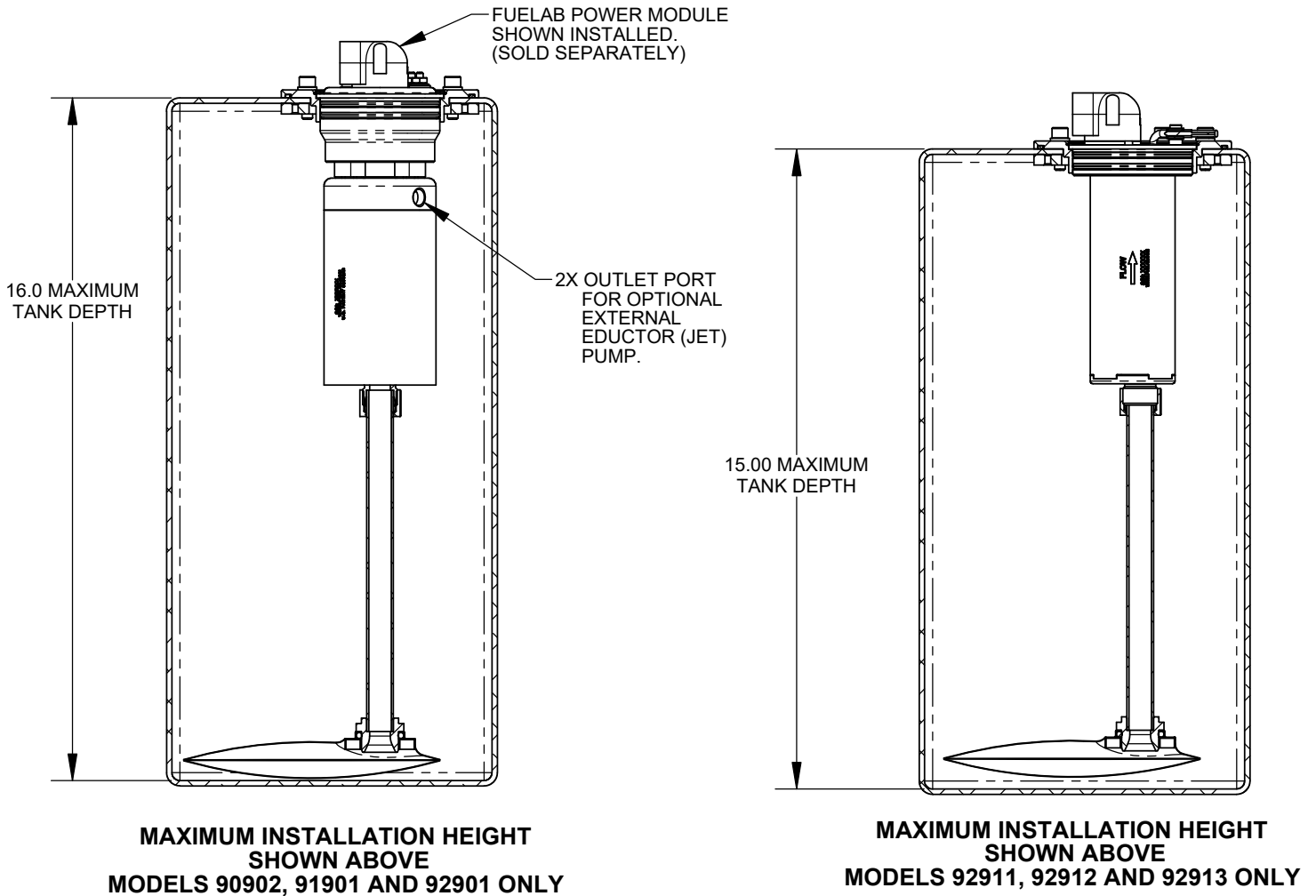

Step 4: WARNING: Vehicle's fuel system may be under pressure! **DO NOT** loosen any fuel connections until relieving all fuel system pressure. Consult an applicable service manual for instructions to relieve fuel system pressure safely. Remove **ALL** Fuel and Fuel vapors from the fuel tank, to allow a safe fabrication of the Fuel Tank. **GASOLINE AND OTHER FUELS ARE FLAMMABLE AND CAN BE EXPLOSIVE!** This step **CANNOT** be overlooked or ignored. While in many cases, it may be safe to perform fabrication while the Fuel Tank remains installed in the vehicle, it may be recommended to remove the Fuel Tank from the vehicle prior to proceeding.

Step 5: Measure and inspect the area of intended installation as described in *Step 3* herein. Use a 3.25 inch diameter (85mm) hole saw or other method of similar precision or better to create a 3.25 inch (85mm) hole into the fuel tank. Deburr the edges of the opening. Use the Flange (Item 1) as a template, to mark holes to be used for the Mounting Cap Screws (Items 11) to pass through during installation. Drill these marked holes using a drill bit between .250 inches in diameter (Drill Size: 1/4", 6.35mm) to .276 inches (Drill Size I, 6.91mm) in diameter. While hand-drills can be used, be as precise as possible, including location. Deburr the edges of the drilled holes.

Step 6: Place the provided O-ring (Ref. Item 3) over the newly created opening of the fuel tank. While keeping the O-ring in a circular shape, inspect the tank surface under and around the O-ring. Inspect the surface for deep scratches or flaws that can cause leakage. Repair surface if required. In some cases two-part epoxies may be used during installation to assist in sealing (still using provided O-ring). Remove the O-ring, and clean any debris from it by hand rinsing under water and allow drying. Wipe the prepped surface of the tank with clean rag.

O-RING MUST FIT INTO GROOVE SHOWN (UNDER FLANGE) FOR PROPER INSTALLATION

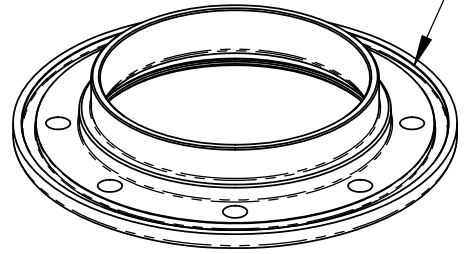

Step 7: Place O-ring back onto surface as described in Step 6. Gently rest the Flange (Item 1) into position as shown in the figure below. The O-ring fits into the groove on the back-side of Flange as shown in the figure to the right. Slip the Cap Screws (Items 11) through the supplied Washers (Items 10), then through the Holes drilled (Reference Step 5). The Cap Screws should pass freely, if not; additional deburring of the holes or use of a round file may be required.

Step 8: Slip one Tank Ring (Item 2) through the opening of the Flange (Item 1). While holding the Tank Ring, lift up into position against the underside of the Fuel Tank (against the Flange too). Move the Tank Ring Around until one of the Cap Screws (Item 11) can be threaded. Once this Cap Screw is threaded (2 to 5 turns), the remaining corresponding Cap Screws can then be threaded (2 to 5 turns). Once the Cap Screws are threaded (four of them), they can be threaded and tightened (finger-tight). **BE SURE TO NOTE THE POSITION OF THE O-RING TO ENSURE THAT IT IS IN THE GROOVE SHOWN IN ABOVE FIGURE.**

Step 9: Repeat Steps 7 and 8 for the remaining Tank Ring (Item 2) and Cap Screws (Items 11).

Step 10: Using a cross-torque method of tightening, tighten all Cap Screws (Items 11) between 40 and 60 in-lbs.

SURFACE THAT O-RING CONTACTS MUST HAVE GOOD SURFACE FINISH!
O-RING FITS AND SEALS AROUND THE 8X THRU HOLES DRILLED FOR THE MOUNTING HARDWARE

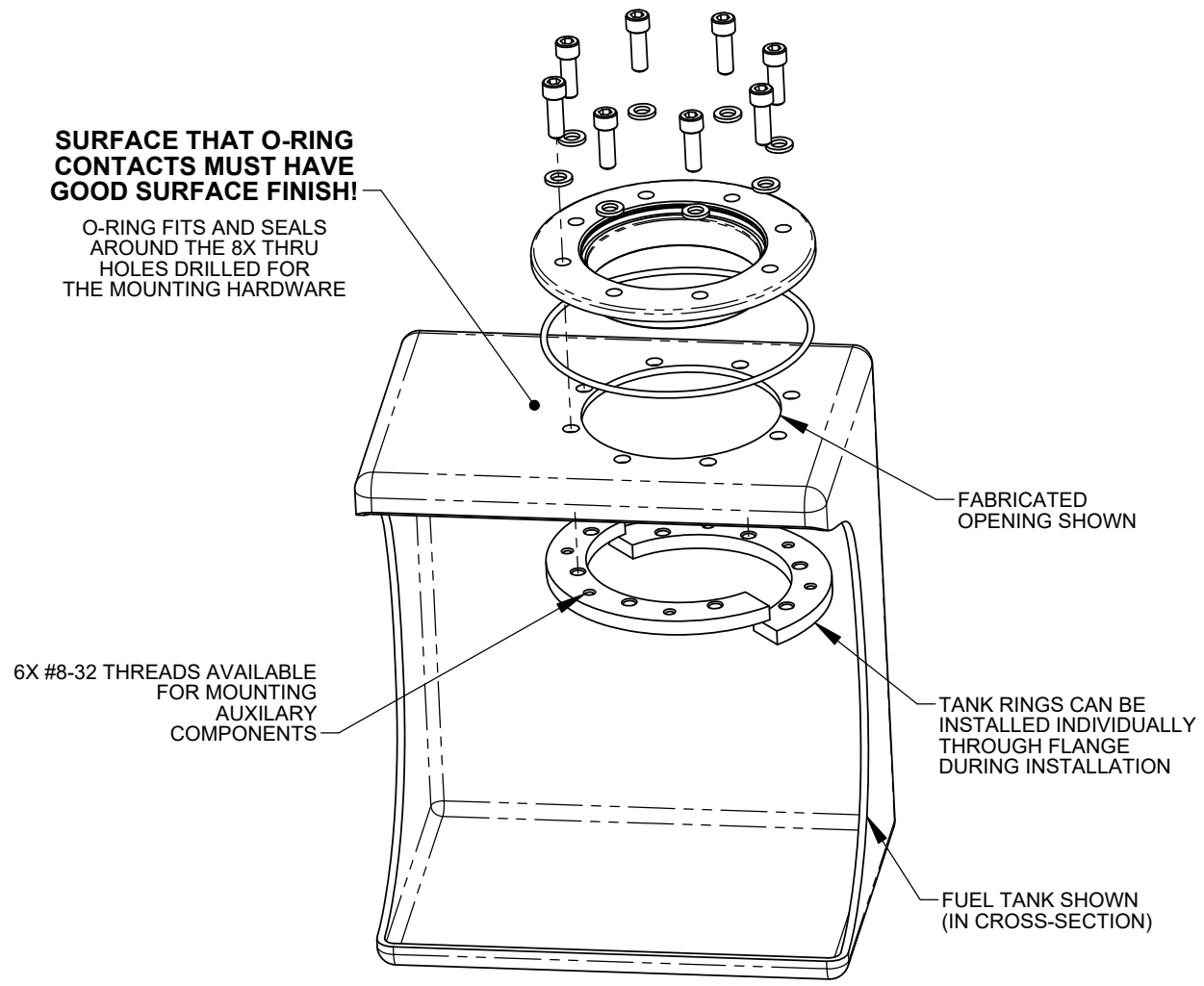

Step 11: Using a straight edge and a tape measure, measure the depth of the fuel tank as shown in the figure below. Write down this value here:

_____ INCHES

then take this above value and subtract: **8.50 (8-1/2) INCHES** for Models 90902, 91901 and 92901 or use **7.50 (7-1/2) INCHES** for Models 92911, 92912 and 92913. This is the new value for the length of the tube measurement for cutting (in *Step 12*, herein). Write down this new value here (for convenience):

_____ INCHES

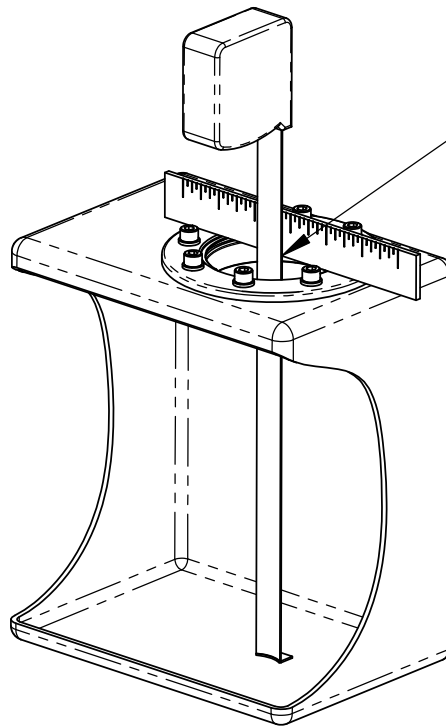

USING STRAIT EDGE AND TAPE MEASURE, MEASURE THE DEPTH OF TANK AT THE CENTER OF THE FLANGE OPENING AS SHOWN.

READING FOR DEPTH IS ON TAPE MEASURE, AT END OF ARROW SHOWN

FOR CONVIENIENCE, WRITE THE MEASURED VALUE ABOVE IN STEP 11. PERFORM THE CALCULATION TOO

Step 12: Using the calculated value from *Step 11* (second value obtained, after subtraction), measure and mark the Pick-Up Tube Assembly (Item 4) as shown below. Use a Pipe Cutting Tool, to cut the tube at the marked position, to achieve the correct installation length for the Pick-Up Tube Assembly as measured in *Step 11*. Deburr the end of the tube, to remove any hanging chips. Use compress air to remove any debris from operation as well.

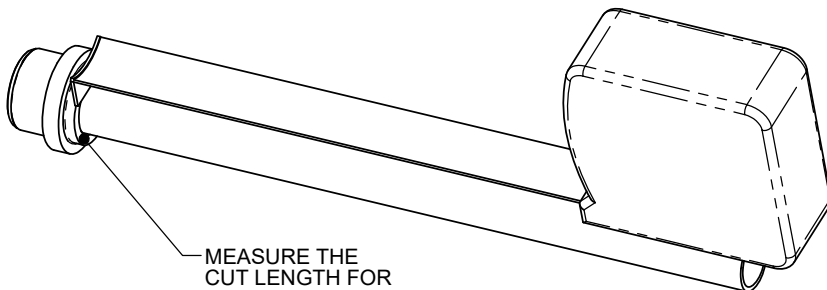

MEASURE THE CUT LENGTH FOR PICK-UP TUBE FROM THIS SURFACE AS SHOWN

MEASURE TWICE, CUT ONCE!

DOUBLE CHECK ALL MEASUREMENTS!

Step 13: Place a spanner wrench (span: 2" using 5/32" Pin maximum) such as available through McMaster-Carr per P/N 5794A16, into a bench vice. Set the Inlet Fitting Adapter (Item 9) into The Spanner Wrench to provide counter-torque as shown in the figure to the right. Slip the Pick-Up Tube (modified in Step 12) into the threaded end of the Inlet Fitting Adapter, while having the Compression Nut (Item 5) and Compression Ferrule (Item 6) slipped over the tube as shown in the Figure to the right.

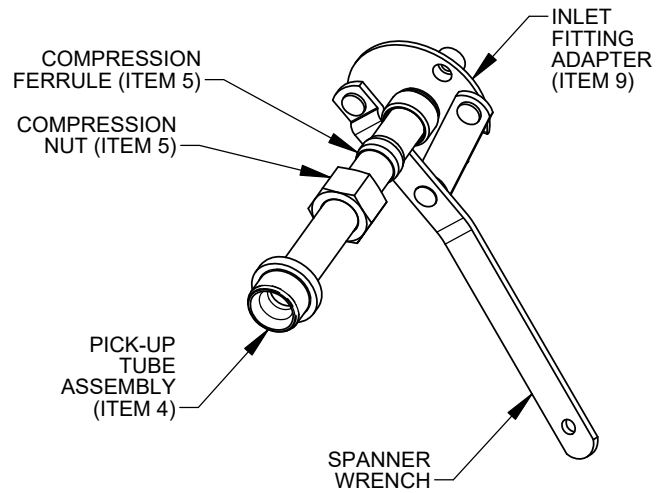

Step 14: Thread the Compression Nut (Item 5) into the Inlet Fitting Adapter (Item 9) and Torque between 10 and 15 ft.-lbs.

Step 15: Lubricate O-ring (Item 12) and slip onto the corresponding O-ring groove on the Inlet Fitting Adapter (Item 9). Note (this o-ring may already be installed). Slip the end of the Inlet Fitting Adapter (with the Pick-up Tube Assembly) into the Power Module. **BE SURE TO ALIGN WINDOW FEATURE OF THE INLET FITTING ADAPTER AROUND THE MOTOR WIRES DURING INSTALLATION. DO NOT DAMAGE MOTOR WIRES!** Use the Cap Screws (Items 7) and thread into the Power Module, to secure the Inlet Fitting Adapter and Pick-Up Tube Assembly. Tighten Cap Screws between 20 and 35 in.-lbs of torque. **SPECIAL NOTE:** Power Modules per Models 92911, 92912 and 92913 to not use the component: Inlet Fitting Adapter and corresponding -015 O-ring.

Step 16: Lubricate the O-rings (2X -146 O-ring from Power Module) and slip over the end and onto the o-ring glands of the Power Module (Fuel Pump). Push on the Straining Filter (Item 8) onto the end of the Inlet Fitting Adapter as shown in the Figure below.

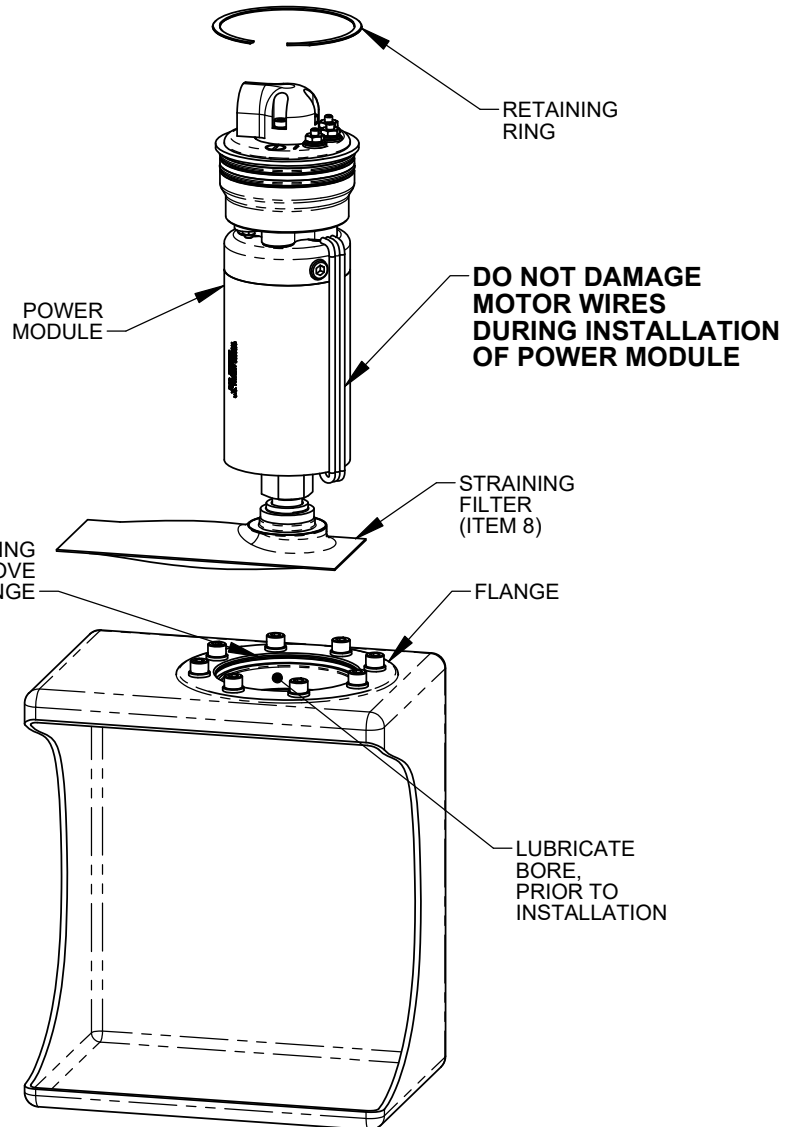

Step 17: This is a good chance to double check the length of the Power Module Assembly and the depth of the Tank (as Described in Step 11). Lubricate the bore of the Flange (Item 1) and carefully insert the Power Module Assembly into the Flange.

Step 18: Orientate the Outlet Fitting of the Power Module Assembly to the desired orientation. Slip the Retaining Ring (from the Power Module sold separately) into the corresponding groove in the Flange (Item 1). Retaining Ring will snap in place when correctly inserted. The Retaining Ring can be removed as well for easy maintenance.

Step 19: Follow all instructions included in the Power Module (sold separately) for wiring and plumbing.

LIMITED LIFETIME WARRANTY

FUELAB, a division of FCP, Inc., having its principal place of business at **1605 Eastport Plaza Drive, Suite 125, Collinsville, IL 62234, USA** ("Manufacturer") warrants its **FUELAB** products (the "Products") as follows:

1. Limited Lifetime Warranty

Manufacturer warrants that the Products sold hereunder will be free from defects in material and workmanship from the date of purchase for so long as the original purchaser owns the Products. This Limited Lifetime Warranty does not extend to any subsequent owner or transferee of the Products. If the Products do not conform to this Limited Lifetime Warranty during the warranty period (as herein above specified), Buyer shall notify Manufacturer in writing of the claimed defects and demonstrate to Manufacturer's satisfaction that said defects are covered by this Limited Lifetime Warranty. If the defects are properly reported to Manufacturer within the warranty period, and the defects are of such type and nature as to be covered by this Limited Lifetime Warranty, Manufacturer shall, at its option and own expense, furnish replacement Products or replacement parts for the defective Products or refund the purchase price. Removal of Products from vehicle, shipping to Manufacturer and installation of the replacement Products or replacement parts shall be at purchaser's expense. (*Vehicle means any automotive, bike or marine transportation device powered by an internal combustion engine to which the Product is attached. This Product is **NOT** intended or designed for use on aircraft, experimental or otherwise.*)

2. Other Limits

THE FOREGOING IS IN LIEU OF ALL OTHER WARRANTIES, EXPRESS OR IMPLIED, INCLUDING BUT NOT LIMITED TO THE IMPLIED WARRANTIES OF MERCHANTABILITY AND FITNESS FOR A PARTICULAR PURPOSE. This Limited Lifetime Warranty does not cover any damage due to: (a) transportation; (b) storage; (c) improper use; (d) failure to follow instructions for the Products or to perform any preventive maintenance; (e) modification; (f) unauthorized repair; (g) normal wear and tear; or (h) external causes such as accidents, abuse, or other actions beyond Manufacturer's reasonable control. This Limited Lifetime Warranty also does not apply to Products upon which repairs have been effected or attempted by persons other than pursuant to written authorization by Manufacturer. This Limited Lifetime Warranty is not extended if we repair or replace the Products.

3. Exclusive Obligation

THIS LIMITED LIFETIME WARRANTY IS EXCLUSIVE. The sole and exclusive obligation of Manufacturer shall at its option be to repair or replace the defective Products in the manner and for the period provided above or to refund the purchase price. Manufacturer shall not have any other obligation with respect to the Products or any part thereof, whether based on contract, tort, strict liability or otherwise.

4. Other Statements

ORAL OR OTHER WRITTEN STATEMENTS BY MANUFACTURER'S EMPLOYEES, REPRESENTATIVES AND/OR RESELLERS DO NOT CONSTITUTE WARRANTIES, SHALL NOT BE RELIED UPON BY BUYER, AND ARE NOT A PART OF THE CONTRACT FOR SALE OR THIS LIMITED LIFETIME WARRANTY.

5. Entire Obligation

This Limited Lifetime Warranty states the entire obligation of Manufacturer with respect to the Products. If any part of this Limited Lifetime Warranty is determined to be void or illegal, the remainder shall remain in full force and effect.

6. Warranty Service

How Do You Get Service?

If something goes wrong with your Product, contact FUELAB at 618-344-3300, or send an e-mail with proof of purchase to: info@fuelab.com for a Return Authorization Number (RMA). After receiving your RMA send the product postage paid, fully insured, with a brief written description of the problem to:

FUELAB Warranty Department, 1605 Eastport Plaza Drive, Suite 125, Collinsville, IL 62234

We will inspect your Product and contact you within three business days of receipt to give the results of our inspection and an estimate of the labor and/or parts charges required to fix the Product, if applicable. If covered under this Limited Lifetime Warranty, Manufacturer will repair or replace the Product and return it to you at no cost or refund the purchase price. If the Product is NOT covered under this warranty and if you authorize repairs, we will return the repaired Product to you COD, or prepaid via credit card, within three business days. If we find no issues with the returned product and it meets all performance specifications, there will be a \$25 charge to cover technician labor and inspection time. Additional return shipping charges will apply. We will return the repaired Product to you COD, or prepaid via credit card, within three business days.

Limitation of Liability

THE REMEDIES DESCRIBED ABOVE ARE YOUR SOLE AND EXCLUSIVE REMEDIES AND OUR ENTIRE LIABILITY FOR ANY BREACH OF THIS LIMITED LIFETIME WARRANTY, OUR LIABILITY SHALL UNDER NO CIRCUMSTANCES EXCEED THE ACTUAL AMOUNT PAID BY YOU FOR THE DEFECTIVE PRODUCT, NOR SHALL WE UNDER ANY CIRCUMSTANCES BE LIABLE FOR ANY CONSEQUENTIAL, INCIDENTAL, SPECIAL OR PUNITIVE DAMAGES OR LOSSES, WHETHER DIRECT OR INDIRECT.

SOME STATES DO NOT ALLOW THE EXCLUSION OR LIMITATION OF INCIDENTAL OR CONSEQUENTIAL DAMAGES, SO THE ABOVE LIMITATION OR EXCLUSION MAY NOT APPLY TO YOU.