

**NOTES:**

1. THIS DRAWING DESCRIBES THE FUELAB 496xx SERIES IN-TANK DC BRUSHLESS FUEL PUMP.
2. FEATURES INCLUDE:
  - THREE PHASE DC BRUSHLESS MOTOR WITH NEODYMIUM MAGNETS
  - EXTERNAL CONTROLLER (ELECTRONICS) REQUIRED
  - IN-TANK OEM STYLE MOUNTING
  - REGENERATIVE TURBINE PUMPING MECHANISM
  - PACKAGED AS KIT, INCLUDING STRAINING FILTER AND PIGTAIL CONNECTOR
  - REFERENCE 253xx SERIES KIT FOR INCLUSION OF CONTROLLER
3. FUEL COMPATIBILITY INCLUDES:
  - GASOLINE (PUMP OR RACE)
  - METHANOL
  - ETHANOL (INCLUDING E85)
  - DIESEL
4. UNIQUE SERIAL NUMBER DOES NOT CONTAIN DIRECT INFORMATION IN DETERMINING MODEL NUMBER. CONTACT FUELAB FOR DETERMINATION OF MODEL NUMBER BASED ON SERIAL NUMBER.
5. STRAINING FILTER, MATING PIGTAIL ELECTRICAL CONNECTOR, INSTRUCTIONS AND PERFORMANCE CERTIFICATION INCLUDED, BAGGED SERPARATELY FROM PUMP.
6. USE OF EXTERNAL MOTOR CONTROLLER IS REQUIRED USING THREE-WIRE PHASE OUTPUT EMPLOYING NON-SENSOR (SENSORLESS) DRIVE TECHNIQUES. COMPATIBLE WITH 720xx SERIES CONTROLLER.
7. ALL MODEL 496xx SERIES PUMPS REQUIRE BYPASS REGULATOR OR RELIEF VALVE TO AVOID OVER-PRESSURE OPERATING CONDITION (UNLESS BEING USED WITH ELECTRONIC PRESSURE CONTROL).
8. SEE TABLE BELOW FOR DETERMINATION OF DESIRED MODEL NUMBER. MODELS 49604 AND 49614 HAS ADDITIONAL 6mm OUTLET FOR USE WITH JET PUMP (EDUCTOR) SYSTEM. BOTH OUTLETS CONTAIN CHECK VALVE. ALL OTHER PUMPS DO NOT HAVE BUILT IN CHECK VALVES. MODEL 49615 HAS INTEGRATED INLET SIPHON FEATURE TO MATCH OE SYSTEMS THAT USE BRUSHLESS PUMPS SUCH AS BMW, AUDI OR LAMBORGHINI.

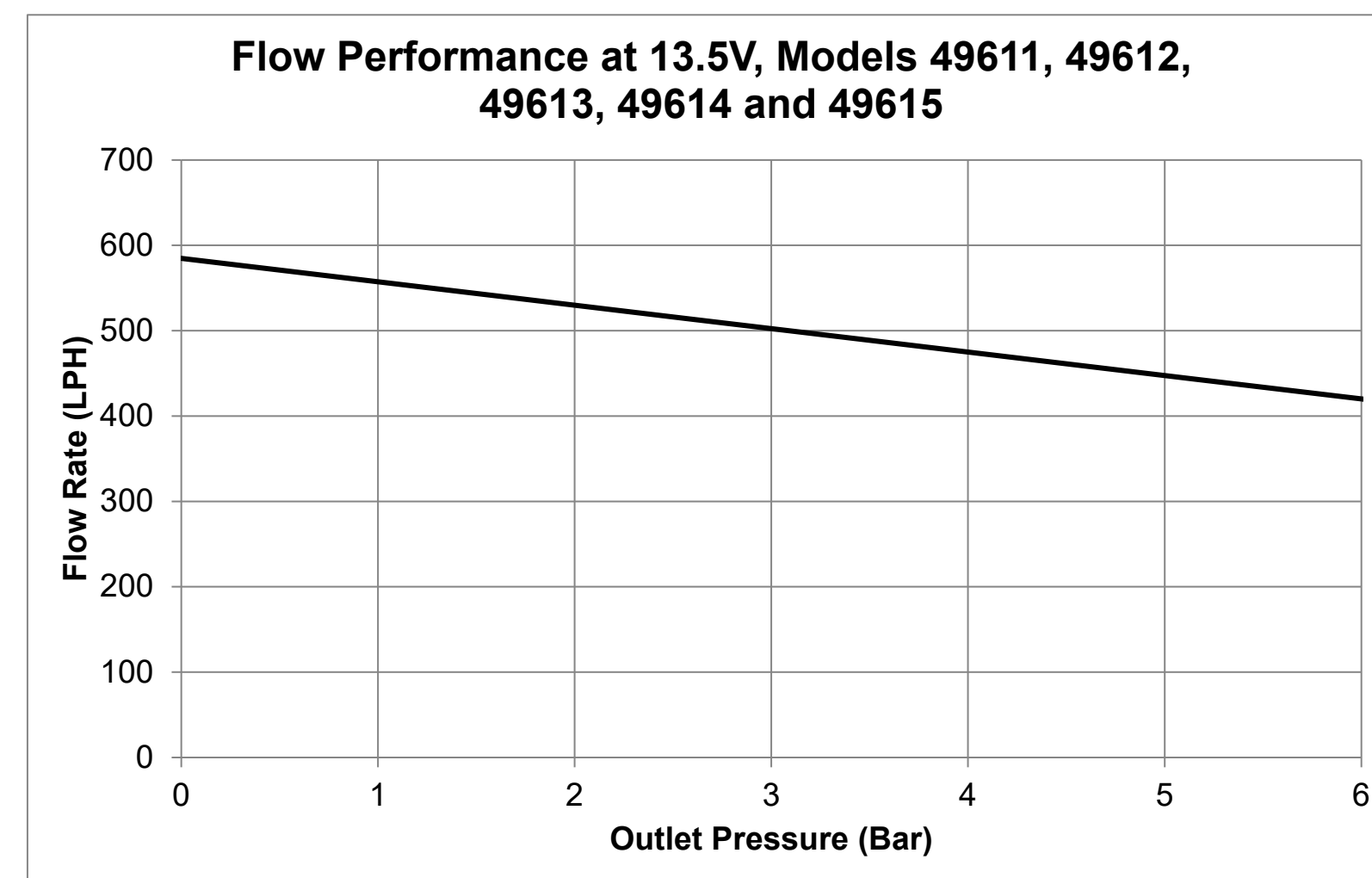
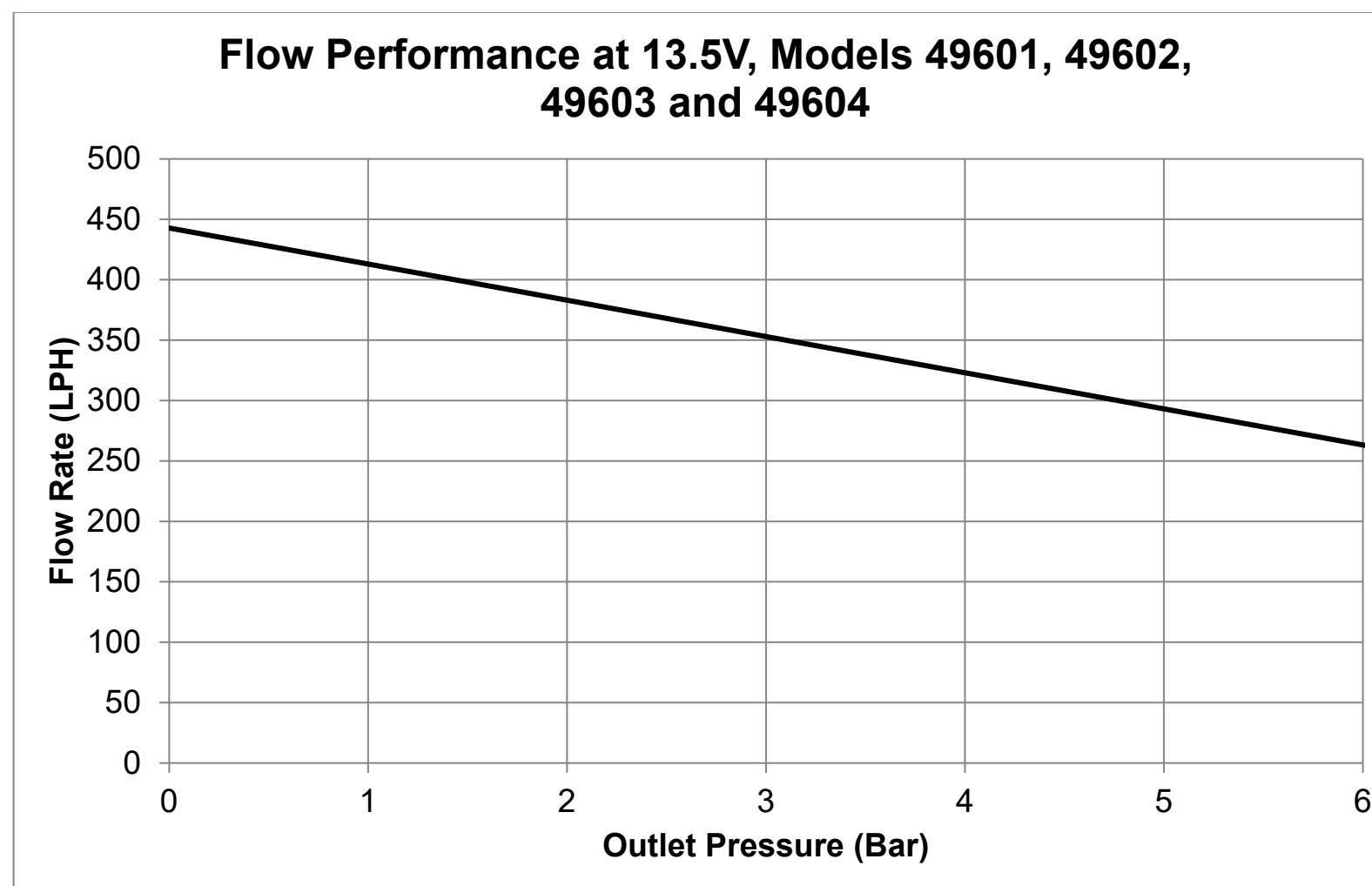

**MODEL SELECTION TABLE**

MODEL	OUTLET TYPE	FLOW RATING, AT 13.8v	MAX. PRESSURE	SPECIAL FEATURES
49601	-6AN	92 GPH AT 45 PSI (350 LPH AT 3.0 BAR)	125 PSI (8.6 BAR)	
49602	5/16" SAE	92 GPH AT 45 PSI (350 LPH AT 3.0 BAR)	125 PSI (8.6 BAR)	
49603	3/8" SAE	92 GPH AT 45 PSI (350 LPH AT 3.0 BAR)	125 PSI (8.6 BAR)	
49604	9mm BARBED	92 GPH AT 45 PSI (350 LPH AT 3.0 BAR)	125 PSI (8.6 BAR)	AUX 6mm BARB SIPHON
49611	-6AN	132 GPH AT 45 PSI (500 LPH AT 3.0 BAR)	125 PSI (8.6 BAR)	
49612	5/16" SAE	132 GPH AT 45 PSI (500 LPH AT 3.0 BAR)	125 PSI (8.6 BAR)	
49613	3/8" SAE	132 GPH AT 45 PSI (500 LPH AT 3.0 BAR)	125 PSI (8.6 BAR)	
49614	9mm BARBED	132 GPH AT 45 PSI (500 LPH AT 3.0 BAR)	125 PSI (8.6 BAR)	AUX 6mm BARB SIPHON
49615	5/16" SAE	132 GPH AT 45 PSI (500 LPH AT 3.0 BAR)	125 PSI (8.6 BAR)	SIPHON STYLE INLET

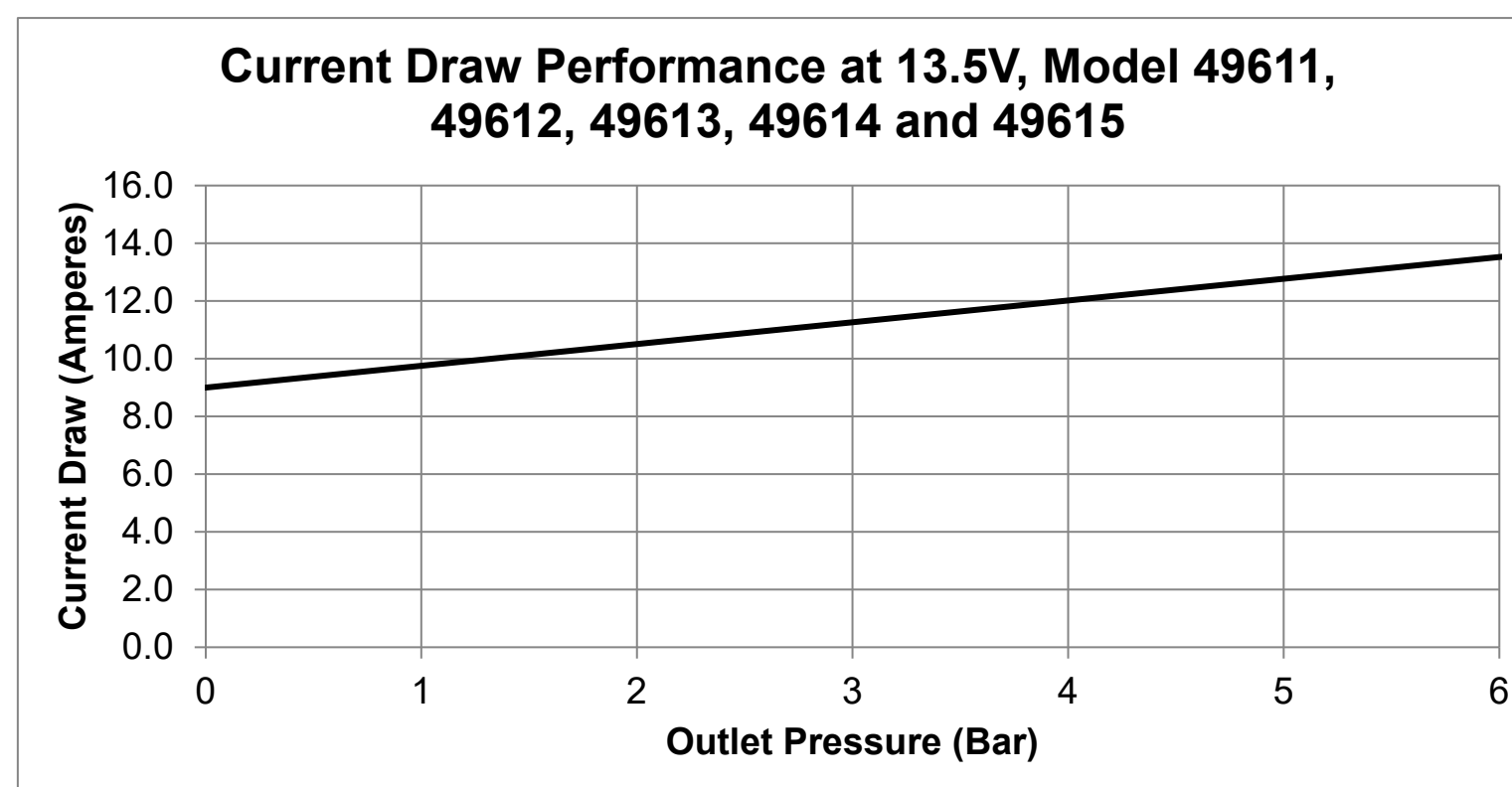
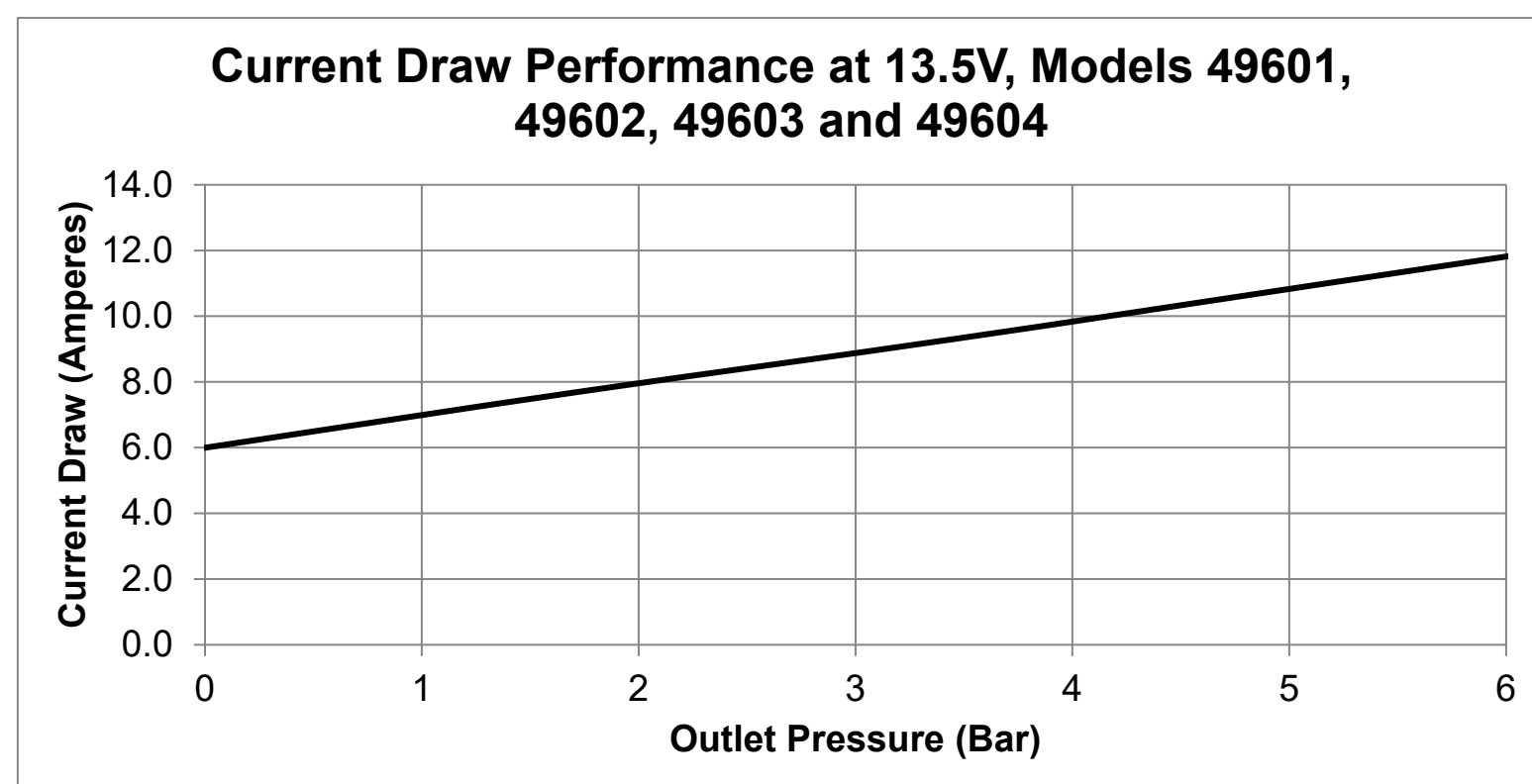
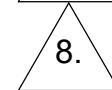

UNLESS OTHERWISE SPECIFIED: INTERPRET DWG PER ANSI Y14.5 DIMENSIONS ARE IN INCHES TOLERANCES: FRACTIONAL: ±1/64" ANGULAR: ±1/2° DECIMALS: X±1 .XX±.03 .XXX±.010 SURFACE FINISH 128 OR BETTER BREAK ALL SHARP EDGES .010 MAX REMOVE ALL BURRS		 COLLINSVILLE, ILLINOIS	
TITLE: <b>ELECTRONIC FUEL PUMP, 496xx SERIES</b>			
SIZE <b>C</b>	DWG. NO. <b>110021300</b>	REV <b>A</b>	
SCALE: 1/1		WEIGHT:	SHEET: 1 OF 6

8 7 6 5 4 3 2 1

F  
E  
D  
C  
B  
A

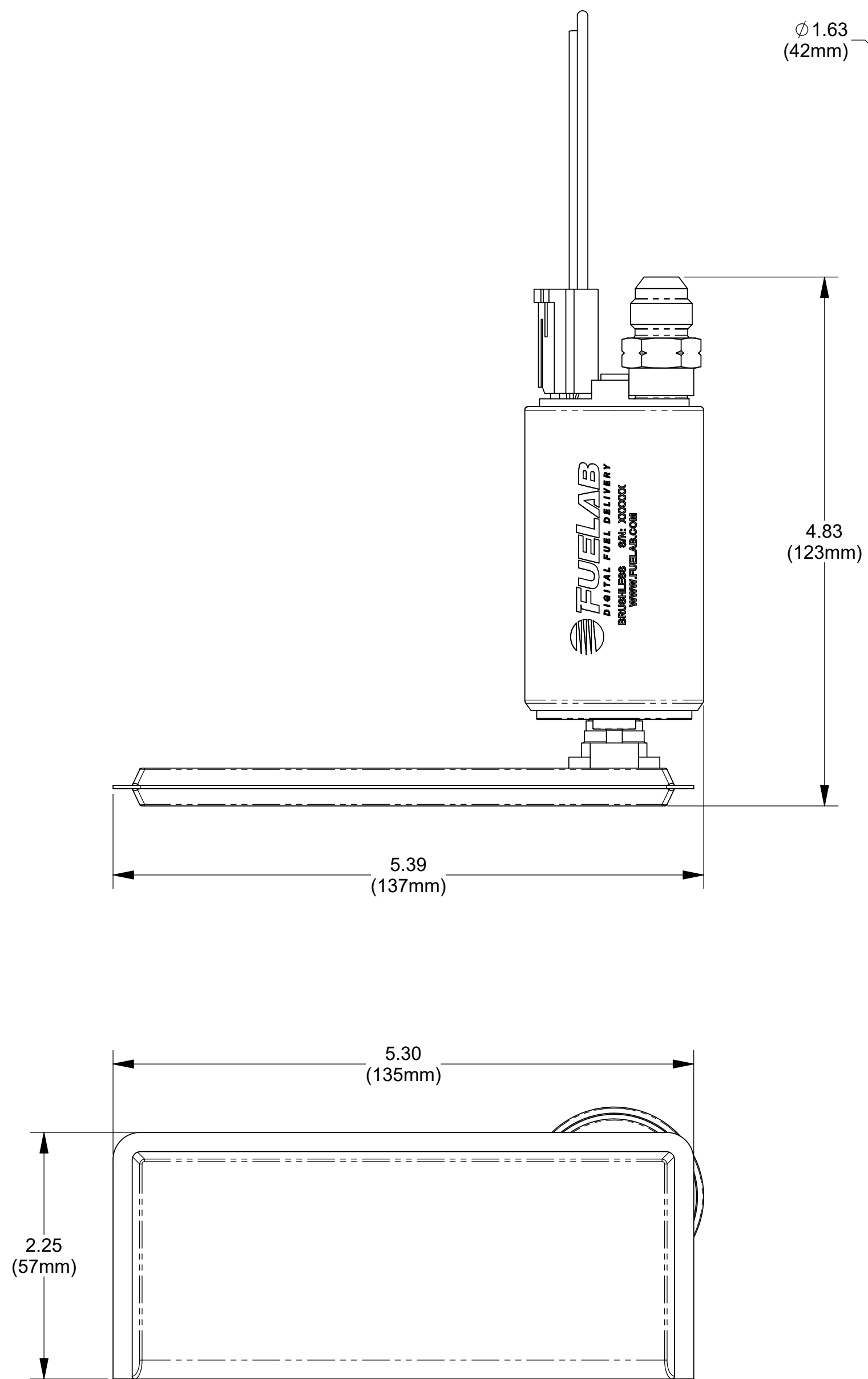

**MODEL 49601 OR 49611 SHOWN ABOVE  
(WITH SUPPLIED ACCESORIES)**

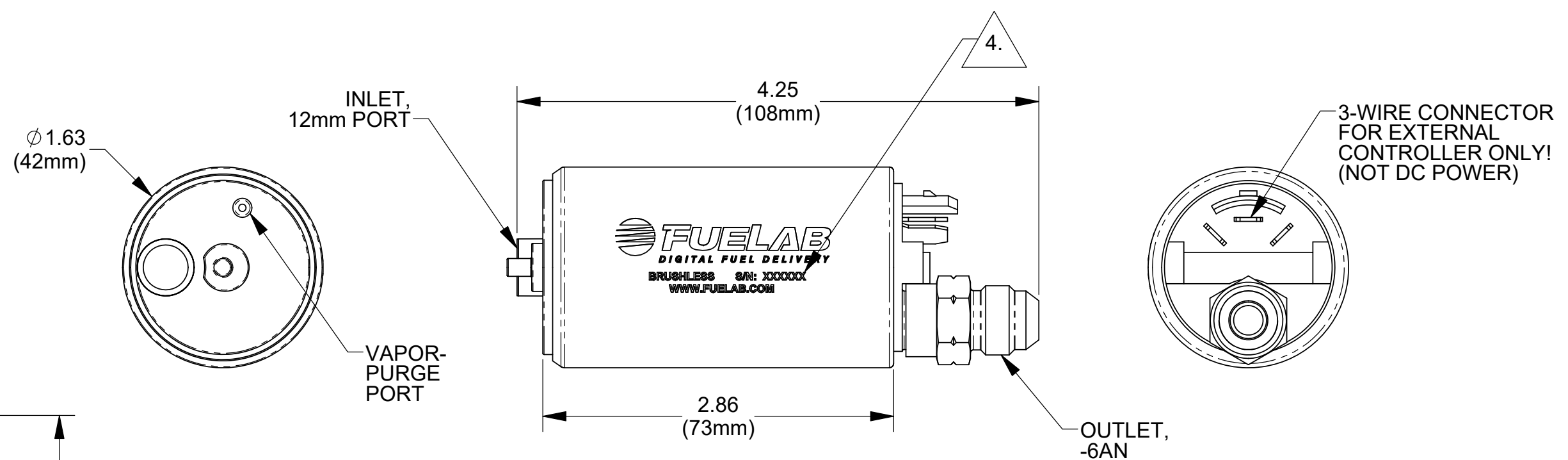

**MODEL 49601 OR 49611 SHOWN ABOVE**

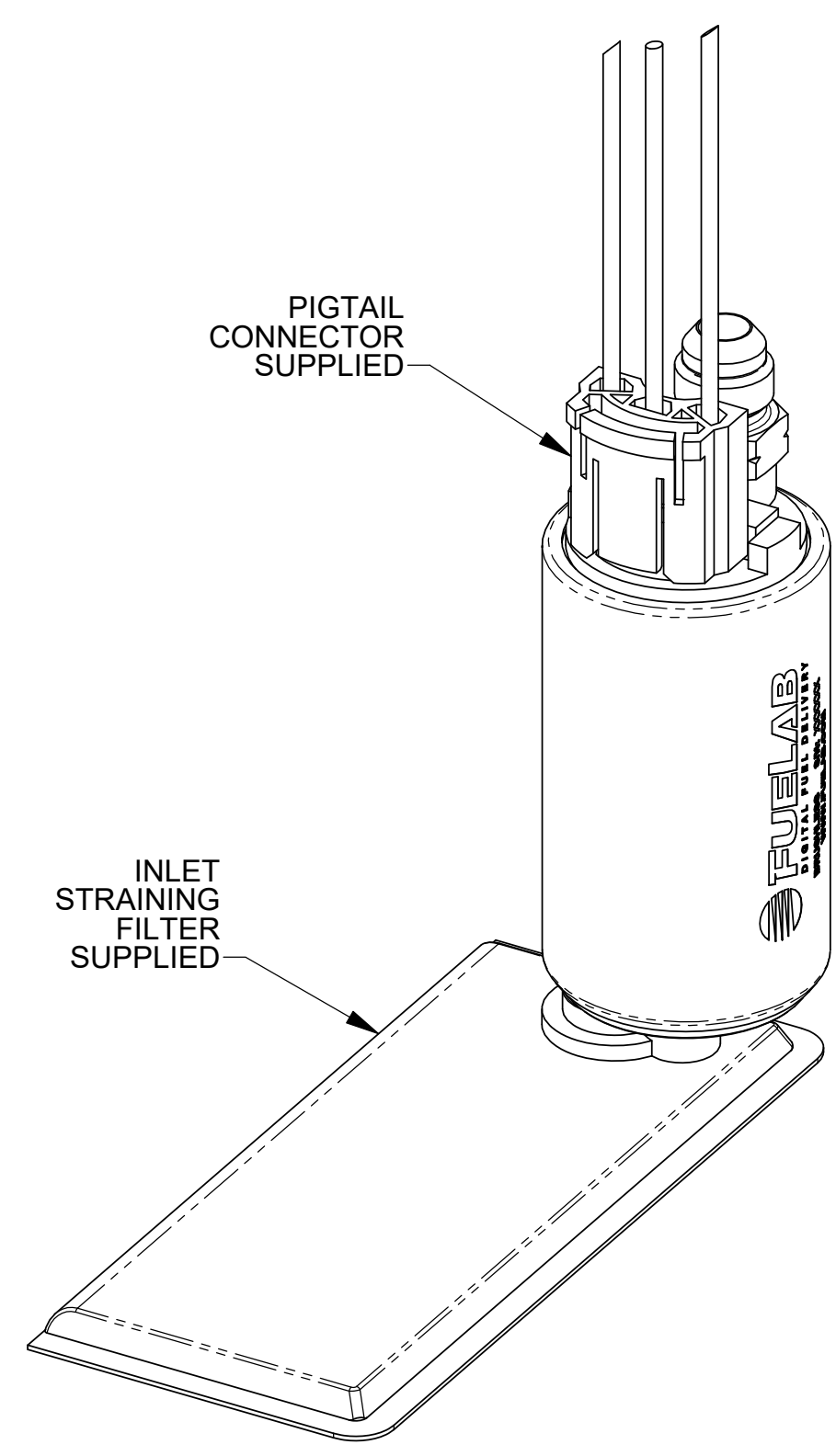

**ISOMETRIC VIEW**

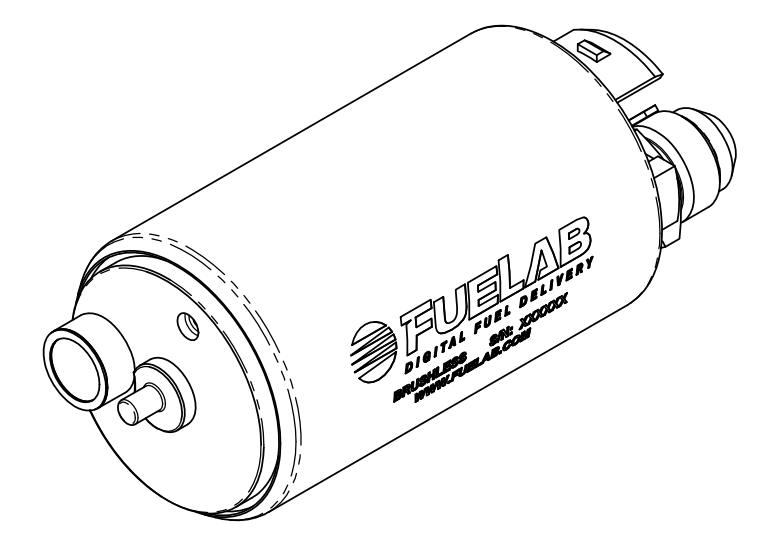

**ISOMETRIC VIEW  
MODEL 49601 OR 49611**

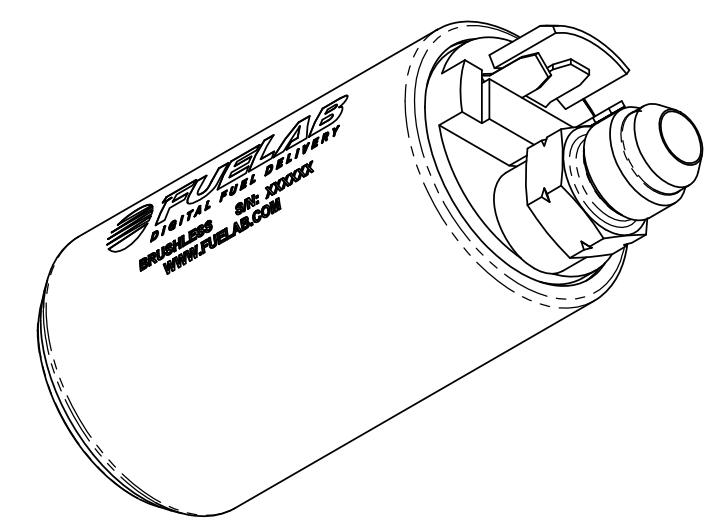

**ALTERNATE ISOMETRIC VIEW  
MODEL 49601 OR 49611**

UNLESS OTHERWISE SPECIFIED:		<b>FUELAB</b> DIGITAL FUEL DELIVERY Collinsville, Illinois	
INTERPRET DWG PER ANSI Y14.5 DIMENSIONS ARE IN INCHES		TITLE: <b>ELECTRONIC FUEL PUMP, 496xx SERIES</b>	
TOLERANCES: FRACTIONAL: ±1/64" ANGULAR: ±1/2° DECIMALS: X±1 .XX±.03 .XXX±.010		SIZE <b>C</b>	DWG. NO. <b>110021300</b>
SURFACE FINISH 128 ✓ OR BETTER		REV <b>A</b>	SCALE: 1/1
BREAK ALL SHARP EDGES .010 MAX REMOVE ALL BURRS		WEIGHT:	SHEET: 2 OF 6
THIRD ANGLE PROJECTION		DO NOT SCALE DRAWING	

8 7 6 5 4 3 2 1

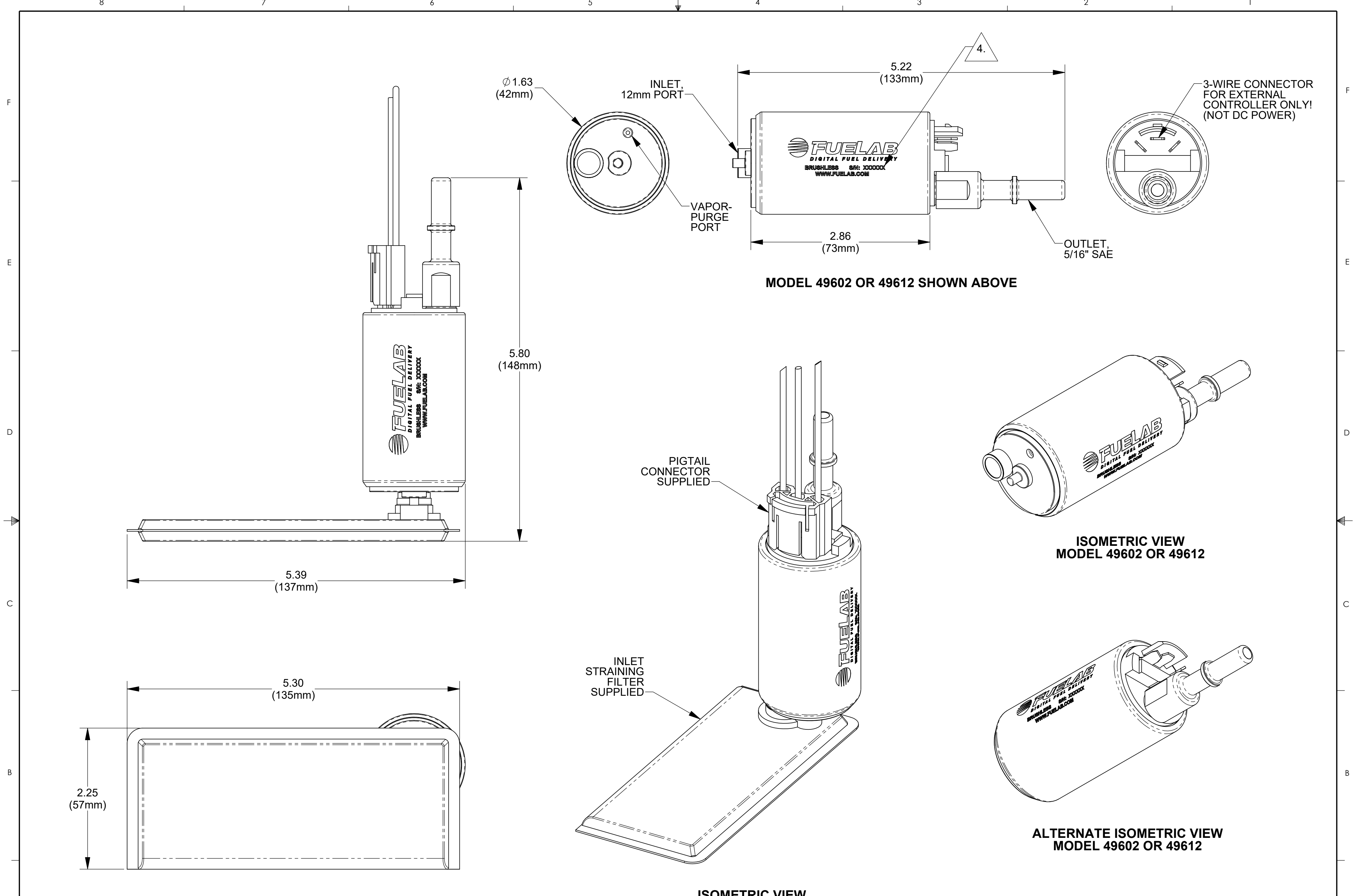

MODEL 49602 OR 49612 SHOWN ABOVE

ISOMETRIC VIEW  
MODEL 49602 OR 49612

ALTERNATE ISOMETRIC VIEW  
MODEL 49602 OR 49612

ISOMETRIC VIEW

MODEL 49602 OR 49612 SHOWN ABOVE  
(WITH SUPPLIED ACCESORIES)

UNLESS OTHERWISE SPECIFIED:		 COLLINSVILLE, ILLINOIS	
INTERPRET DWG PER ANSI Y14.5 DIMENSIONS ARE IN INCHES TOLERANCES: FRACTIONAL: ±1/64" ANGULAR: ±1/2° DECIMALS: X±1 .XX±.03 .XXX±.010 SURFACE FINISH: 128 OR BETTER BREAK ALL SHARP EDGES .010 MAX. REMOVE ALL BURRS			
TITLE: <b>ELECTRONIC FUEL PUMP,          496xx SERIES</b>		SIZE: <b>C</b>	DWG. NO.: <b>110021300</b>
THIRD ANGLE PROJECTION		SCALE: 1/1	REV: <b>A</b>
DO NOT SCALE DRAWING		WEIGHT:	SHEET: 3 OF 6

8 7 6 5 4 3 2 1

F  
E  
D  
C  
B  
A

F  
E  
D  
C  
B  
A

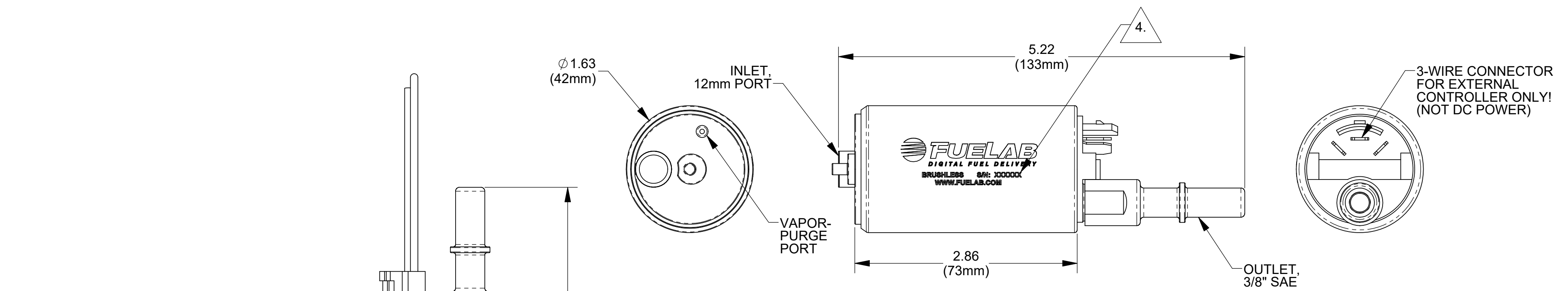

MODEL 49603 OR 49613 SHOWN ABOVE

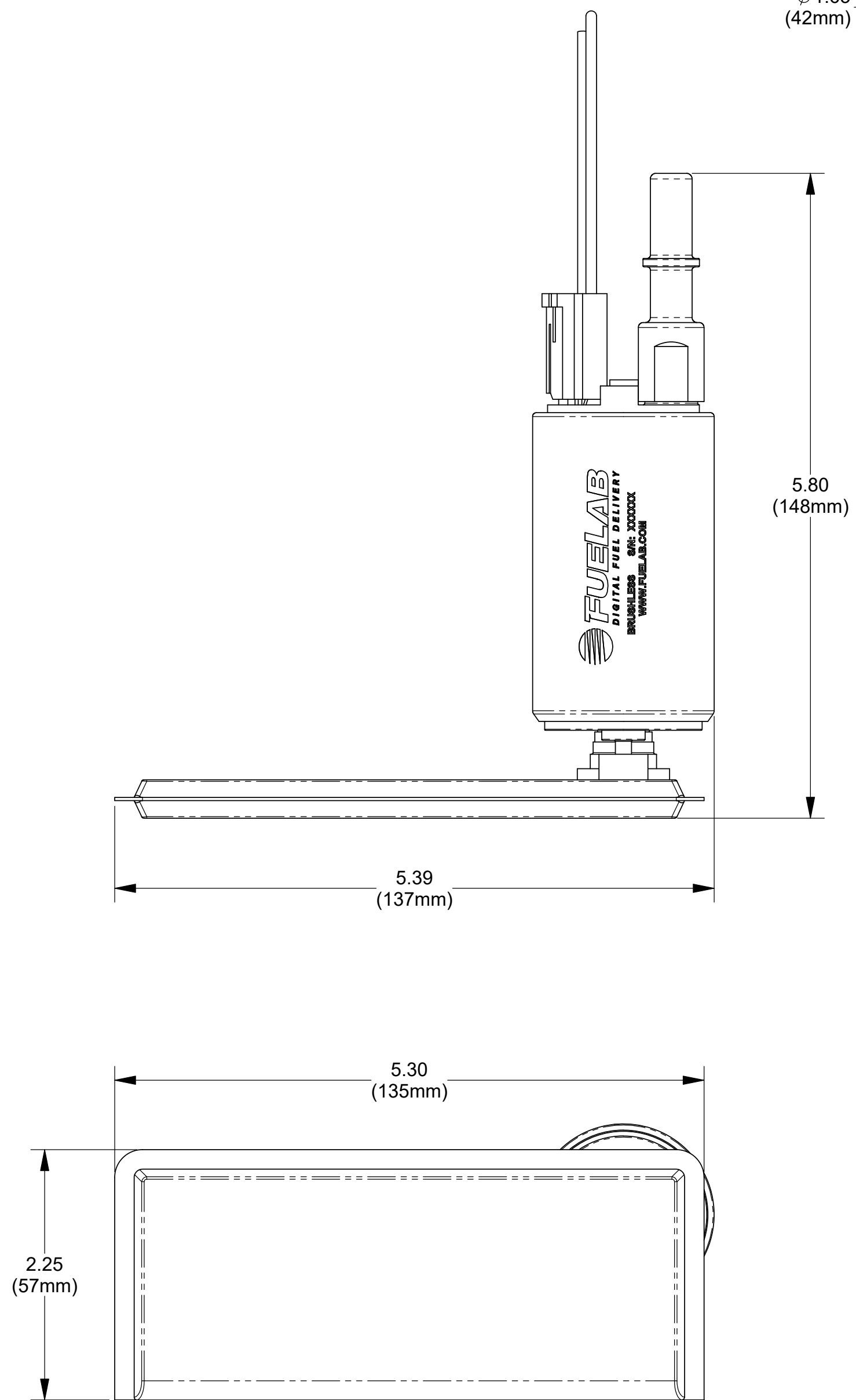

MODEL 49603 OR 49613 SHOWN ABOVE (WITH SUPPLIED ACCESORIES)

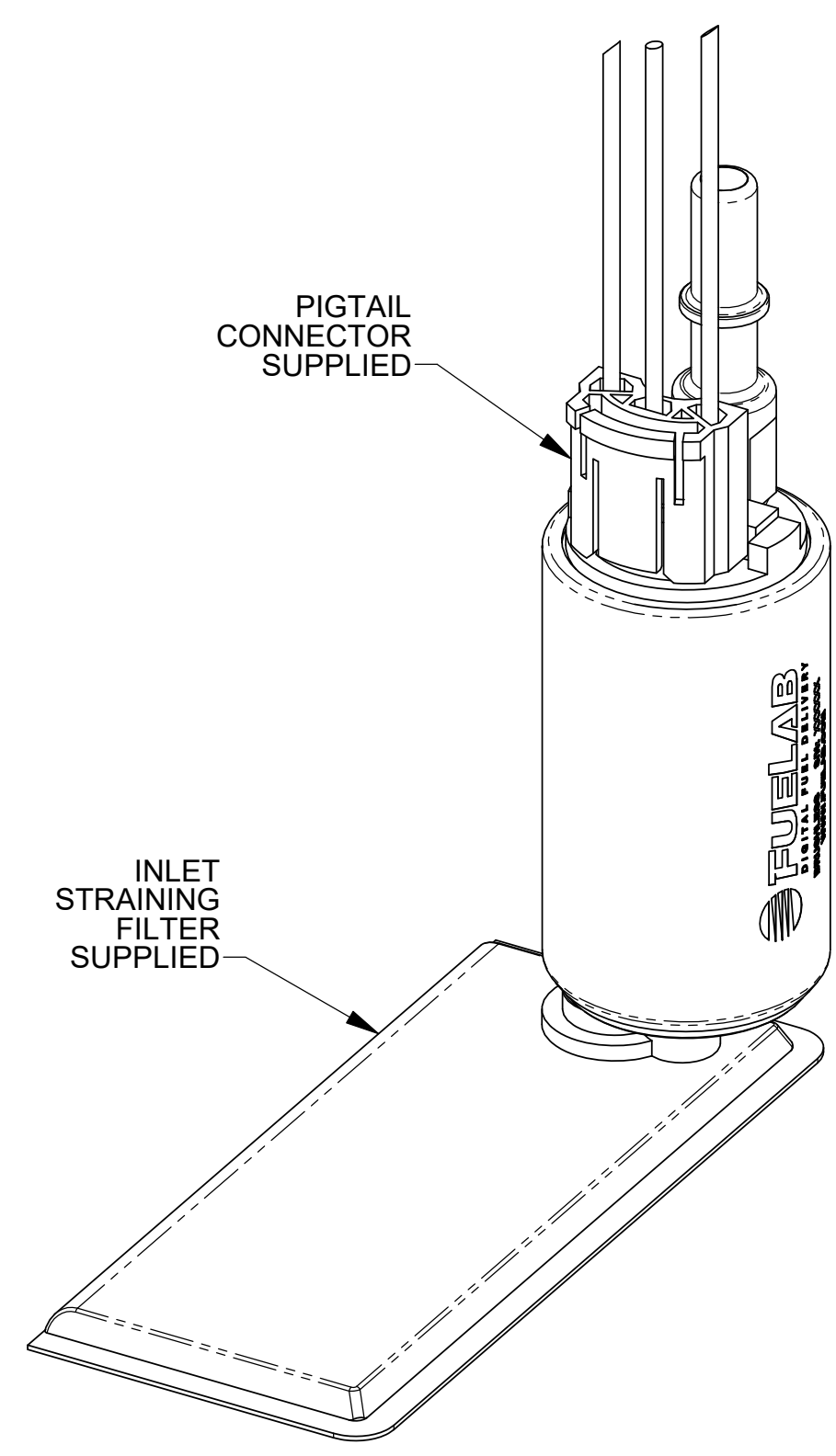

ISOMETRIC VIEW

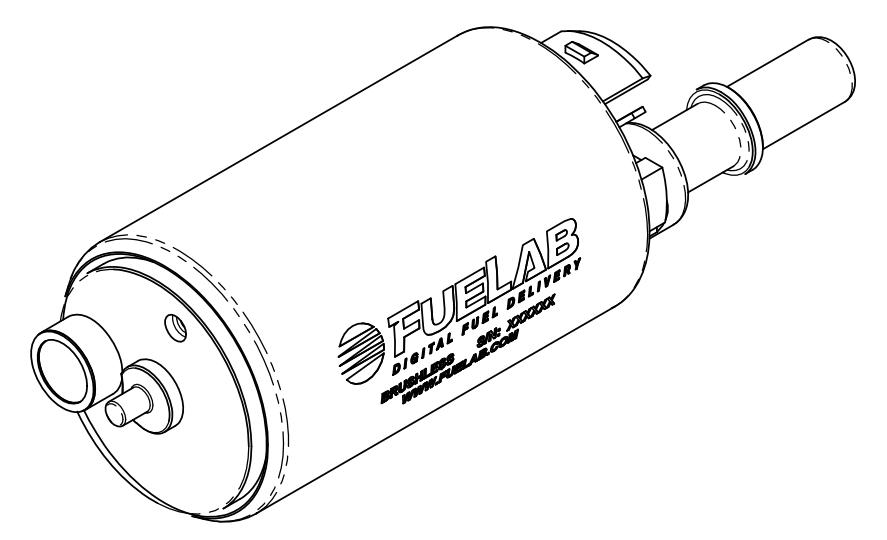

ISOMETRIC VIEW MODEL 49603 OR 49613

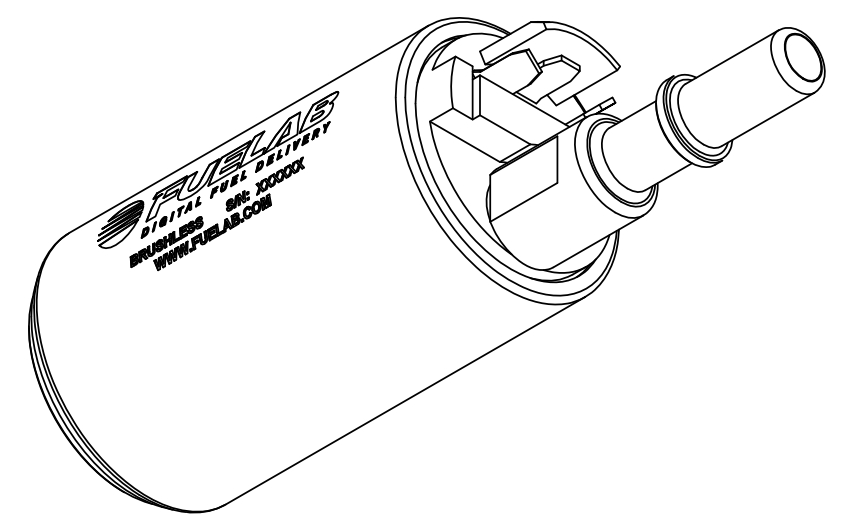

ALTERNATE ISOMETRIC VIEW MODEL 49603 OR 49613

UNLESS OTHERWISE SPECIFIED:		<b>FUELAB</b> DIGITAL FUEL DELIVERY Collinsville, Illinois	
INTERPRET DWG PER ANSI Y14.5 DIMENSIONS ARE IN INCHES		TITLE: <b>ELECTRONIC FUEL PUMP, 496xx SERIES</b>	
TOLERANCES: FRACTIONAL: ±1/64" ANGULAR: ±1/2° DECIMALS: X±1 .XX±.03 .XXX±.010		SIZE <b>C</b>	DWG. NO. <b>110021300</b>
SURFACE FINISH: 128 OR BETTER BREAK ALL SHARP EDGES .010 MAX. REMOVE ALL BURRS		THIRD ANGLE PROJECTION	REV <b>A</b>
DO NOT SCALE DRAWING		SCALE: 1/1	WEIGHT: SHEET: 4 OF 6

8 7 6 5 4 3 2 1

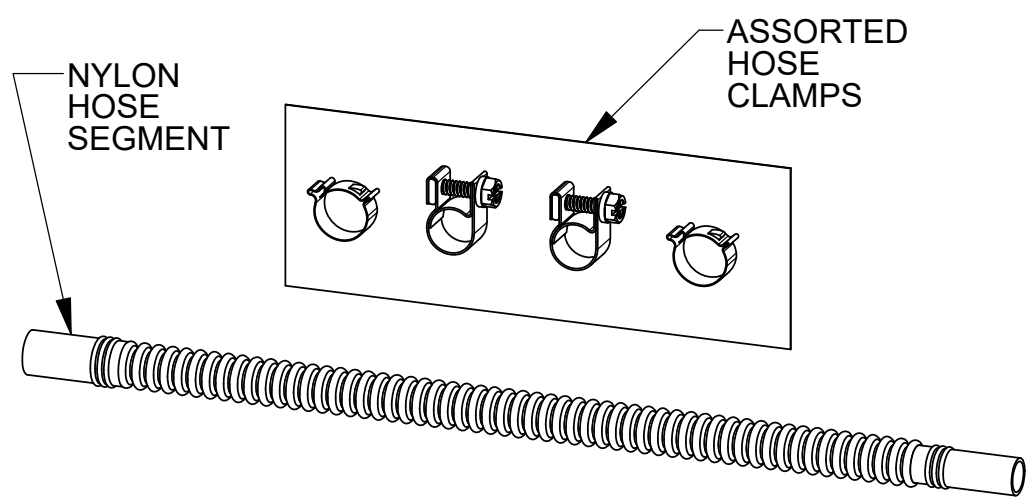

**ADDITIONAL ITEMS INCLUDED FOR MODELS 49604 AND 49614**

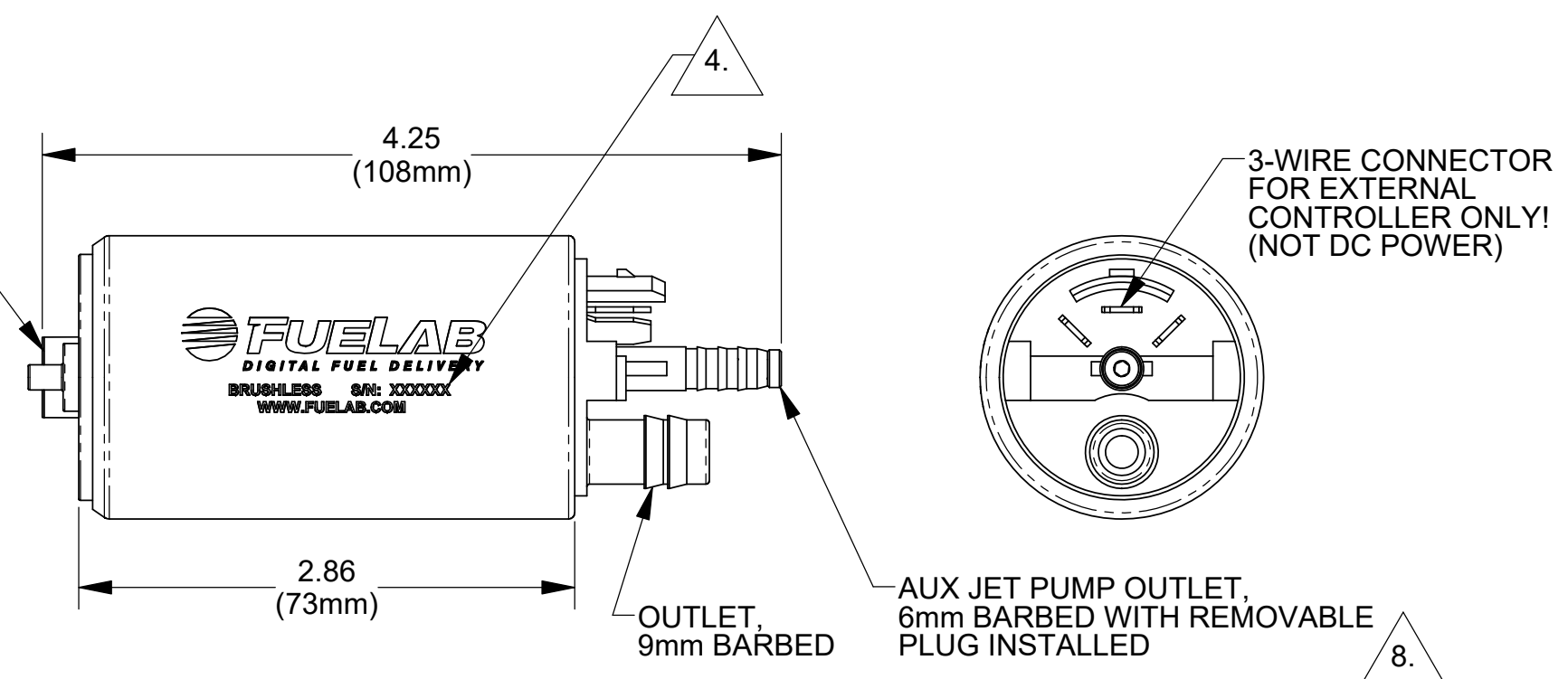
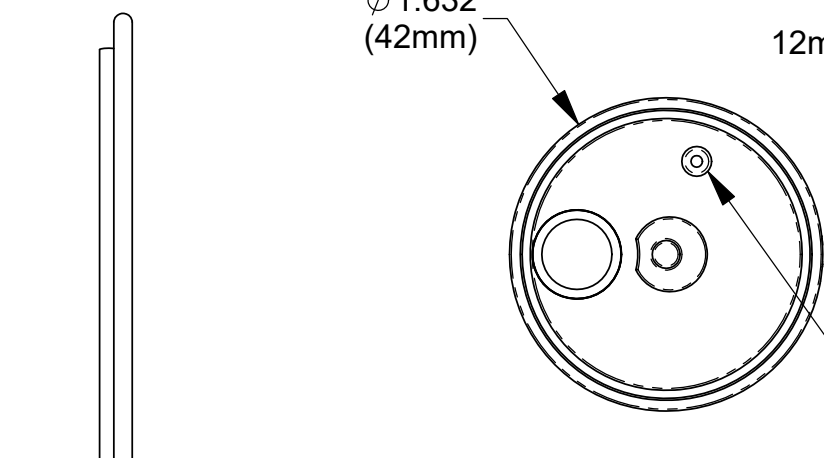

**MODEL 49604 OR 49614 SHOWN ABOVE**

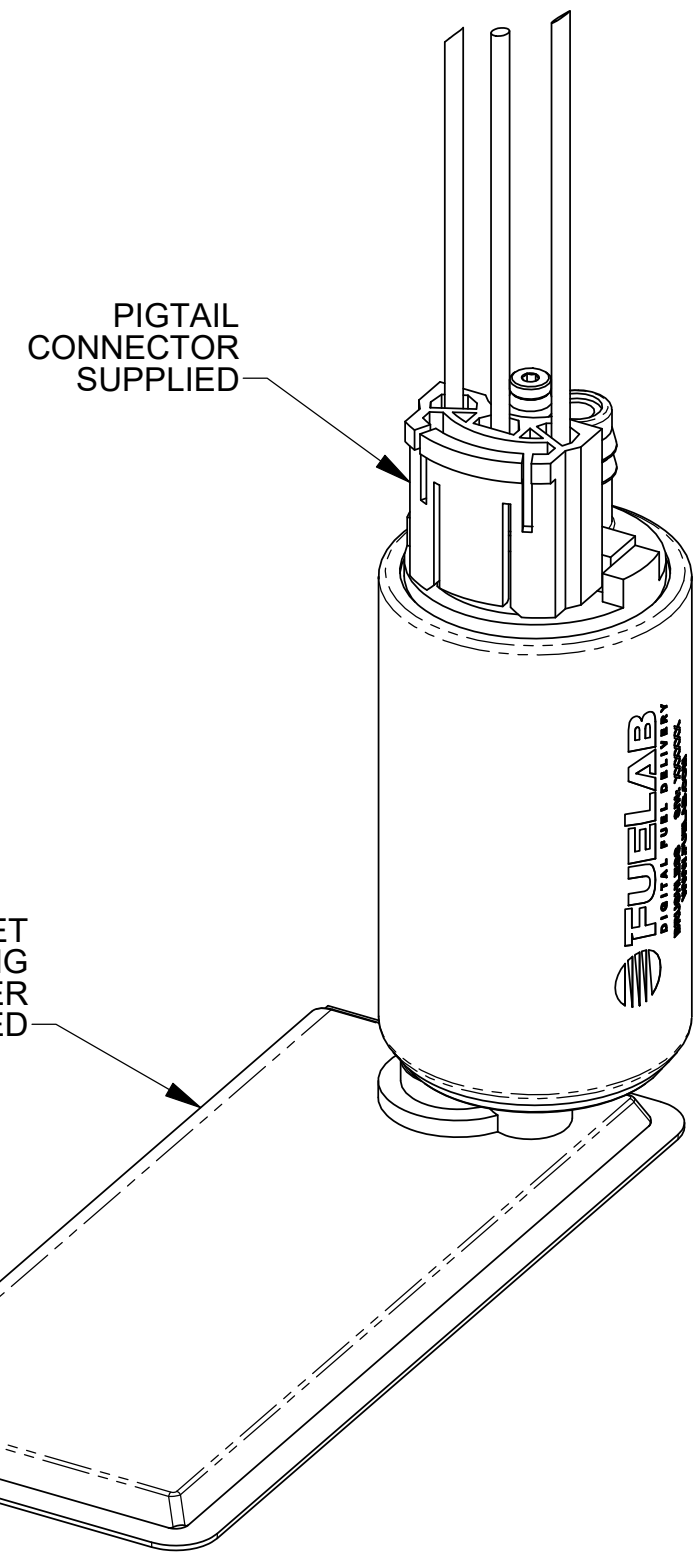
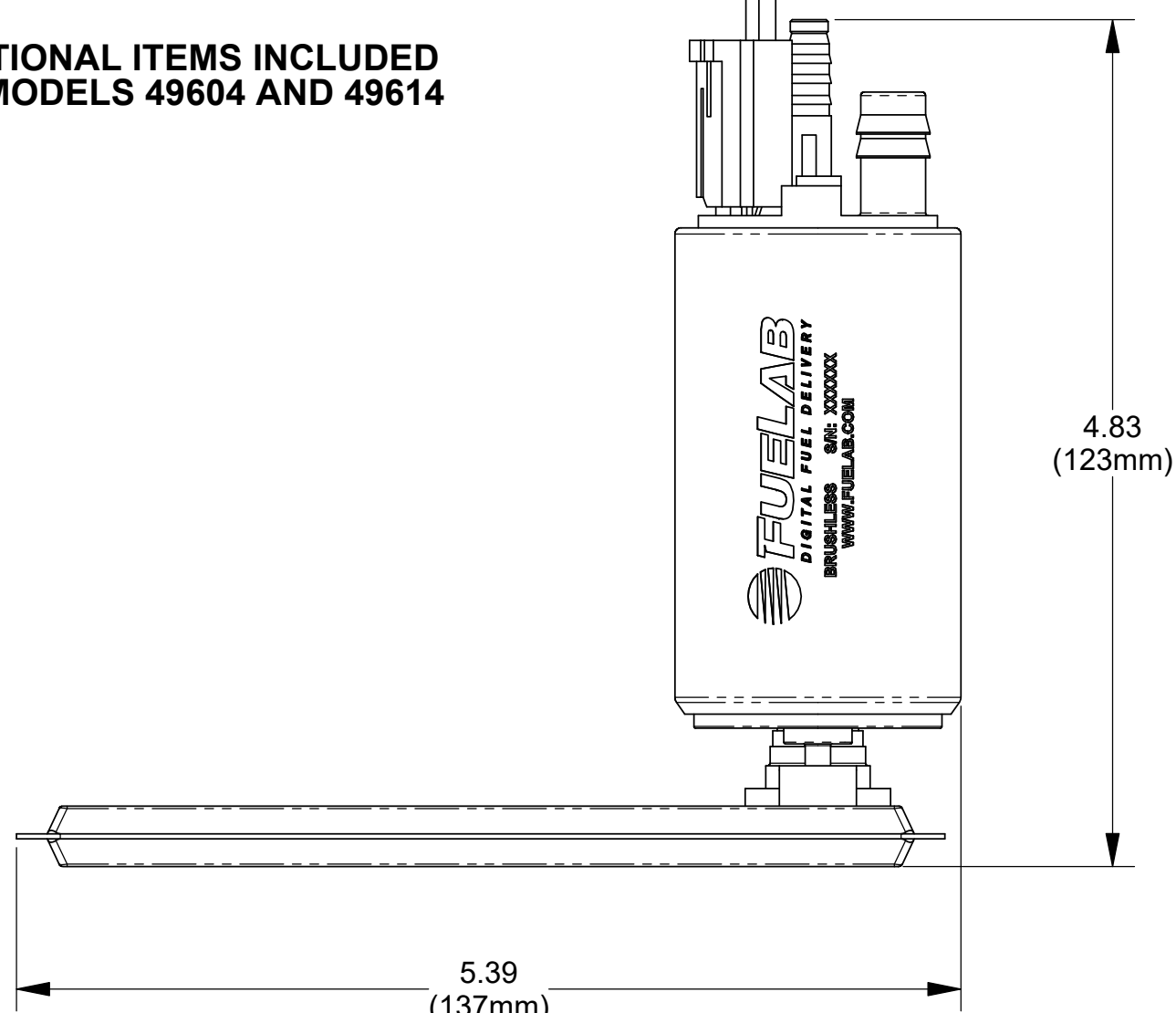

**ISOMETRIC VIEW**

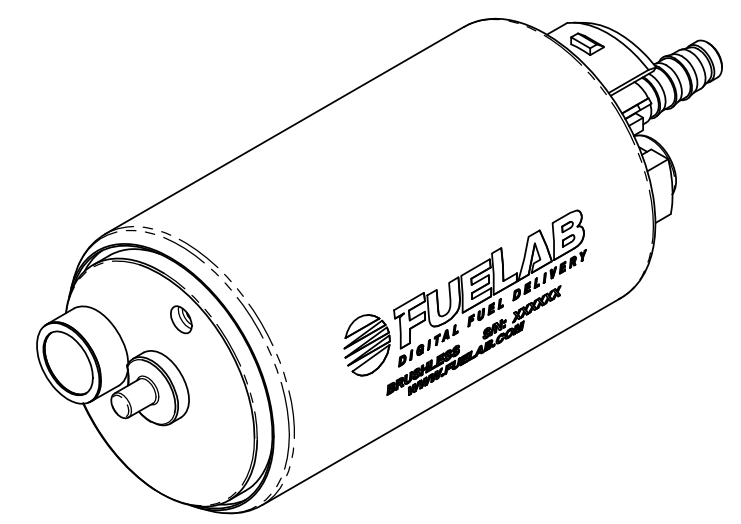

**ISOMETRIC VIEW MODEL 49604 OR 49614**

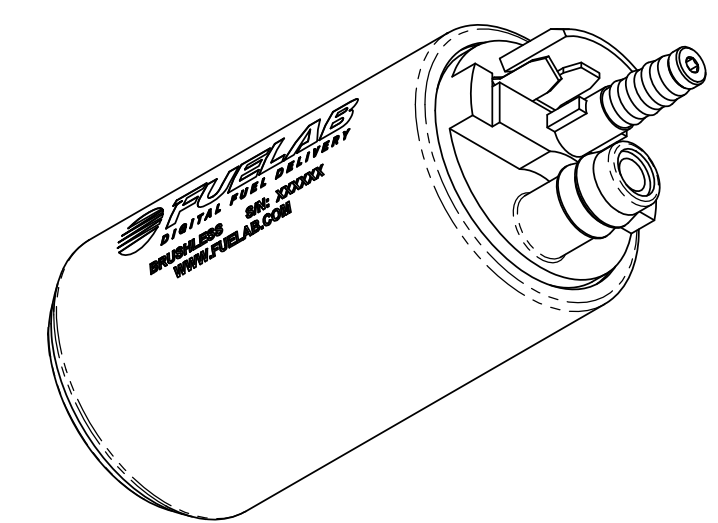

**ALTERNATE ISOMETRIC VIEW MODEL 49604 OR 49614**

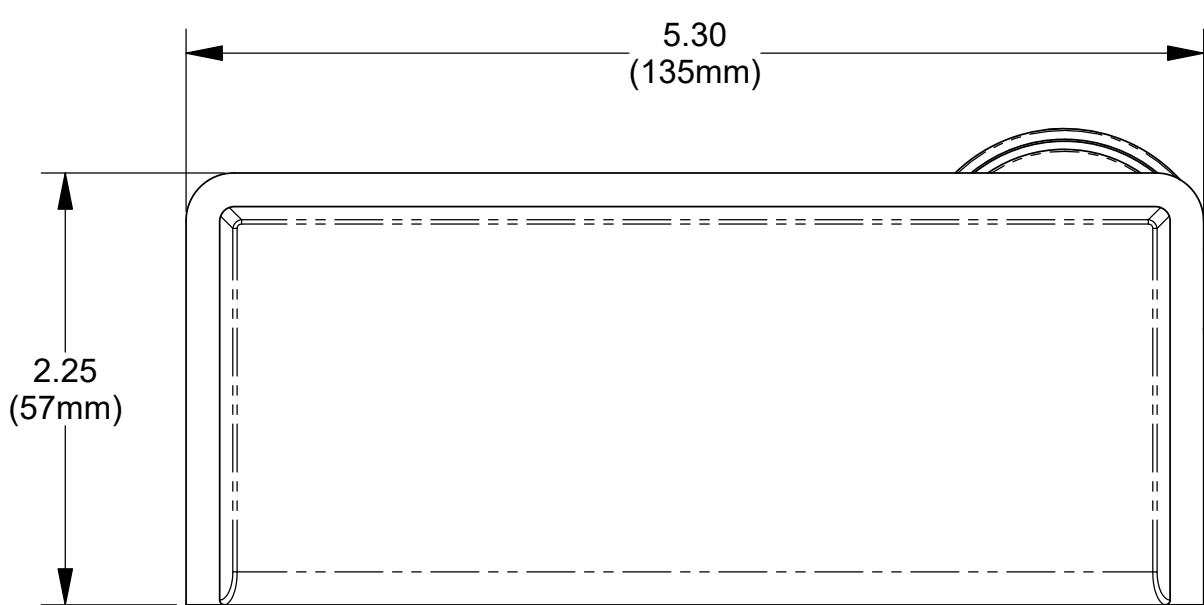

**MODEL 49604 OR 49614 SHOWN ABOVE (WITH SUPPLIED ACCESORIES)**

UNLESS OTHERWISE SPECIFIED:		<b>FUELAB</b> DIGITAL FUEL DELIVERY Collinsville, Illinois	
INTERPRET DWG PER ANSI Y14.5 DIMENSIONS ARE IN INCHES		TITLE: <b>ELECTRONIC FUEL PUMP, 496xx SERIES</b>	
TOLERANCES: FRACTIONAL: ±1/64" ANGULAR: ±1/2° DECIMALS: X±1 .XX±.03 .XXX±.010		SIZE <b>C</b>	DWG. NO. <b>110021300</b>
SURFACE FINISH 128 ✓ OR BETTER		REV <b>A</b>	SCALE: 1/1
BREAK ALL SHARP EDGES .010 MAX REMOVE ALL BURRS		WEIGHT:	SHEET: 5 OF 6
THIRD ANGLE PROJECTION		DO NOT SCALE DRAWING	

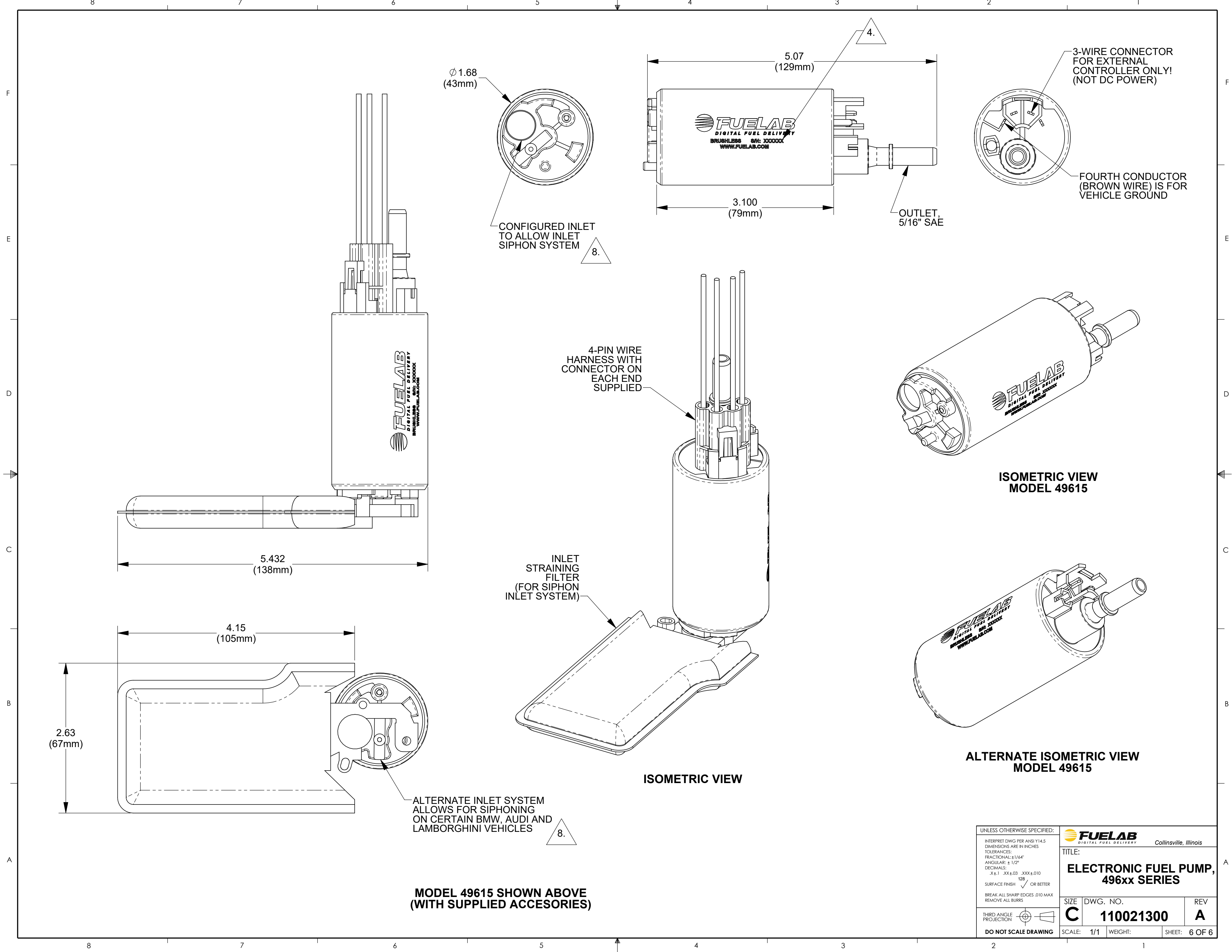

**MODEL 49615 SHOWN ABOVE  
(WITH SUPPLIED ACCESORIES)**

UNLESS OTHERWISE SPECIFIED:		<b>FUELAB</b> <small>DIGITAL FUEL DELIVERY</small> Collinsville, Illinois	
<small>INTERPRET DWG PER ANSI Y14.5          DIMENSIONS ARE IN INCHES          TOLERANCES:          FRACTIONAL: ±1/64"          ANGULAR: ±1/2°          DECIMALS:          X±1 .XX±.03 .XXX±.010          SURFACE FINISH 128 OR BETTER          BREAK ALL SHARP EDGES .010 MAX          REMOVE ALL BURRS</small>			
<small>THIRD ANGLE PROJECTION</small>		<b>SIZE</b> DWG. NO. <b>C</b> 110021300	<b>REV</b> <b>A</b>
<b>DO NOT SCALE DRAWING</b>		SCALE: 1/1	WEIGHT: SHEET: 6 OF 6