

NOTES:

- THIS DRAWING DESCRIBES THE FUELAB 495xx SERIES IN-TANK ELECTRIC FUEL PUMP.
- FEATURES INCLUDE:
 - IN-TANK OEM STYLE MOUNTING
 - ULTRA LOW CURRENT DRAW FUEL TRANSFER AND SCAVENGING
 - PACKAGED AS KIT, INCLUDING STRAINING FILTER.
- FUEL COMPATIBILITY INCLUDES:
 - GASOLINE (PUMP OR RACE)
 - ETHANOL (INCLUDING E85)
 - SPECIAL NOTE: NOT COMPATIBLE WITH METHANOL AND DIESEL FUELS
- UNIQUE SERIAL NUMBER WITH MODEL NUMBER IDENTIFICATION
- STRAINING FILTER, INSTRUCTIONS, BAGGED SERPARATELY FROM PUMP.
- 8-18 VOLT OPERATING RANGE, USE ONLY 12 VOLT (6 CELL LEAD ACID BATTERY) VEHICLE SYSTEMS WITH OR WITHOUT CHARGING SYSTEM.
- SEE TABLE BELOW FOR DETERMINATION OF DESIRED MODEL NUMBER.

MODEL SELECTION TABLE

MODEL	OUTLET PORT SIZE	FLOW RATING, AT 13.8v	MAX. PRESSURE
49501	3/8" NIPPLE	43 GPH AT 2 PSI (160 LPH AT 0.15 BAR)	5 PSI (0.35 BAR)
49502	-6AN	43 GPH AT 2 PSI (160 LPH AT 0.15 BAR)	5 PSI (0.35 BAR)
49503	3/8" SAE	43 GPH AT 2 PSI (160 LPH AT 0.15 BAR)	5 PSI (0.35 BAR)

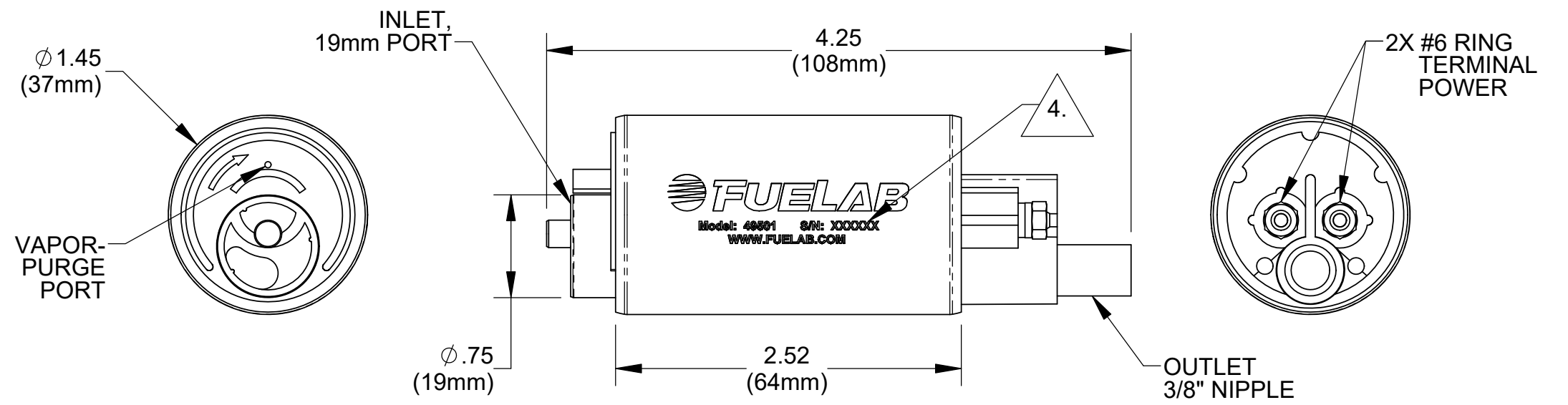

MODEL 49501 SHOWN ABOVE

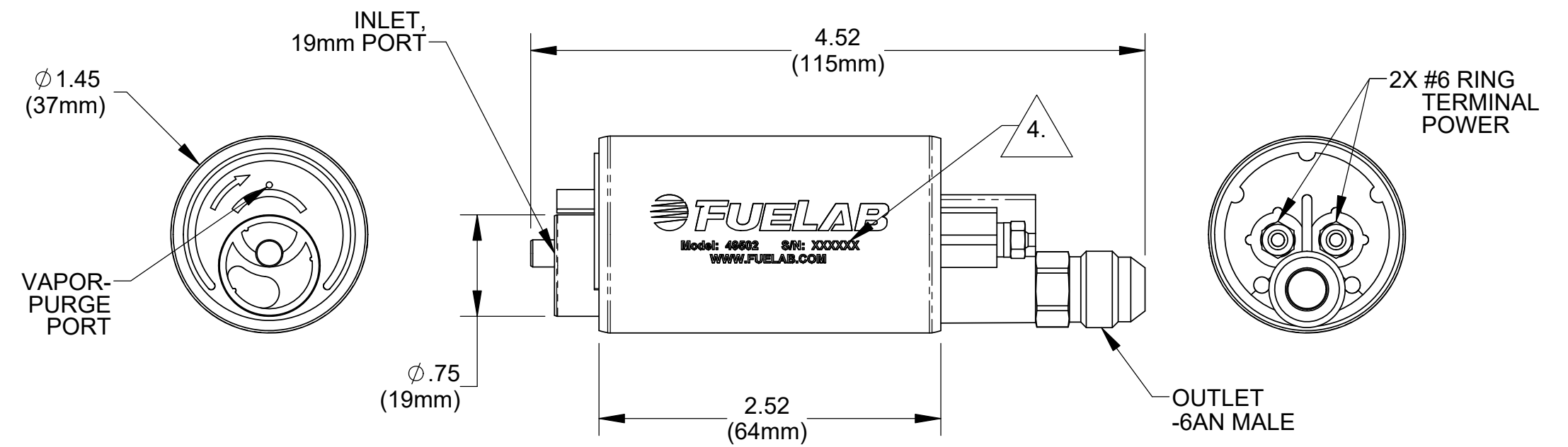

MODEL 49502 SHOWN ABOVE

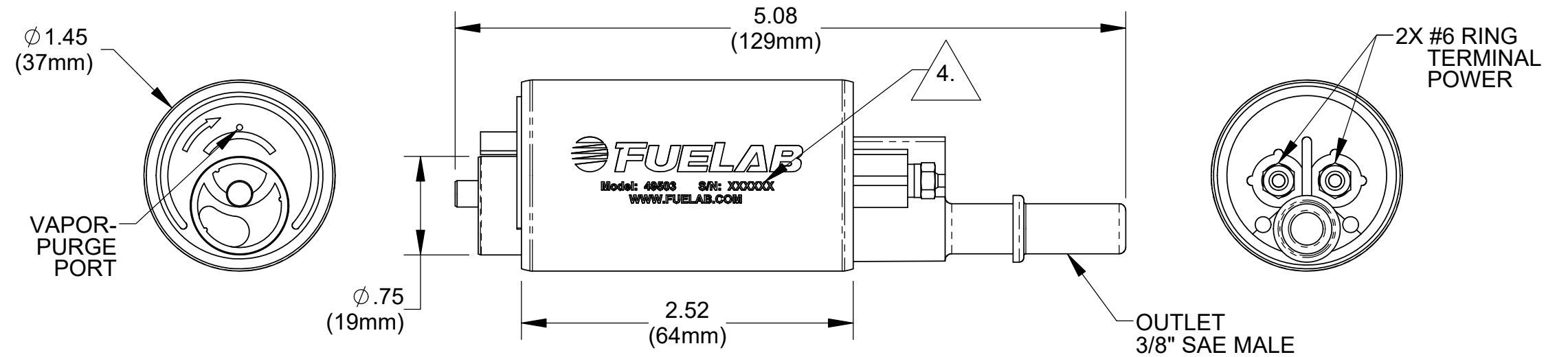

MODEL 49503 SHOWN ABOVE

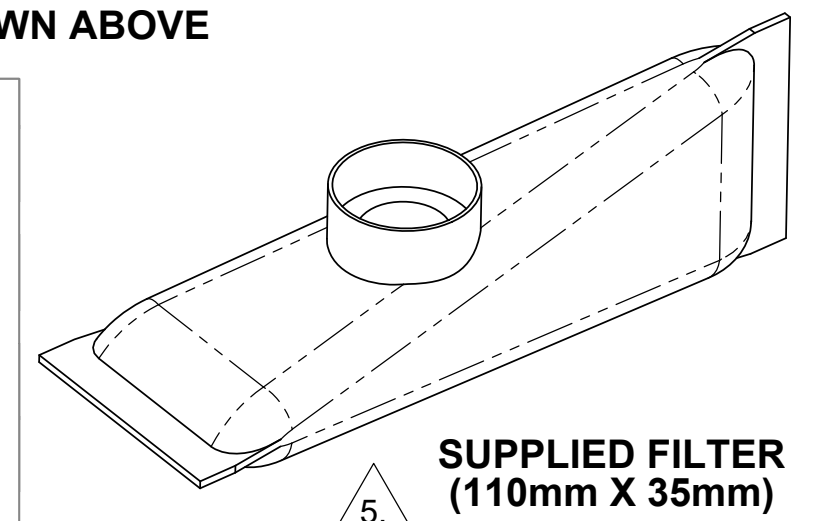
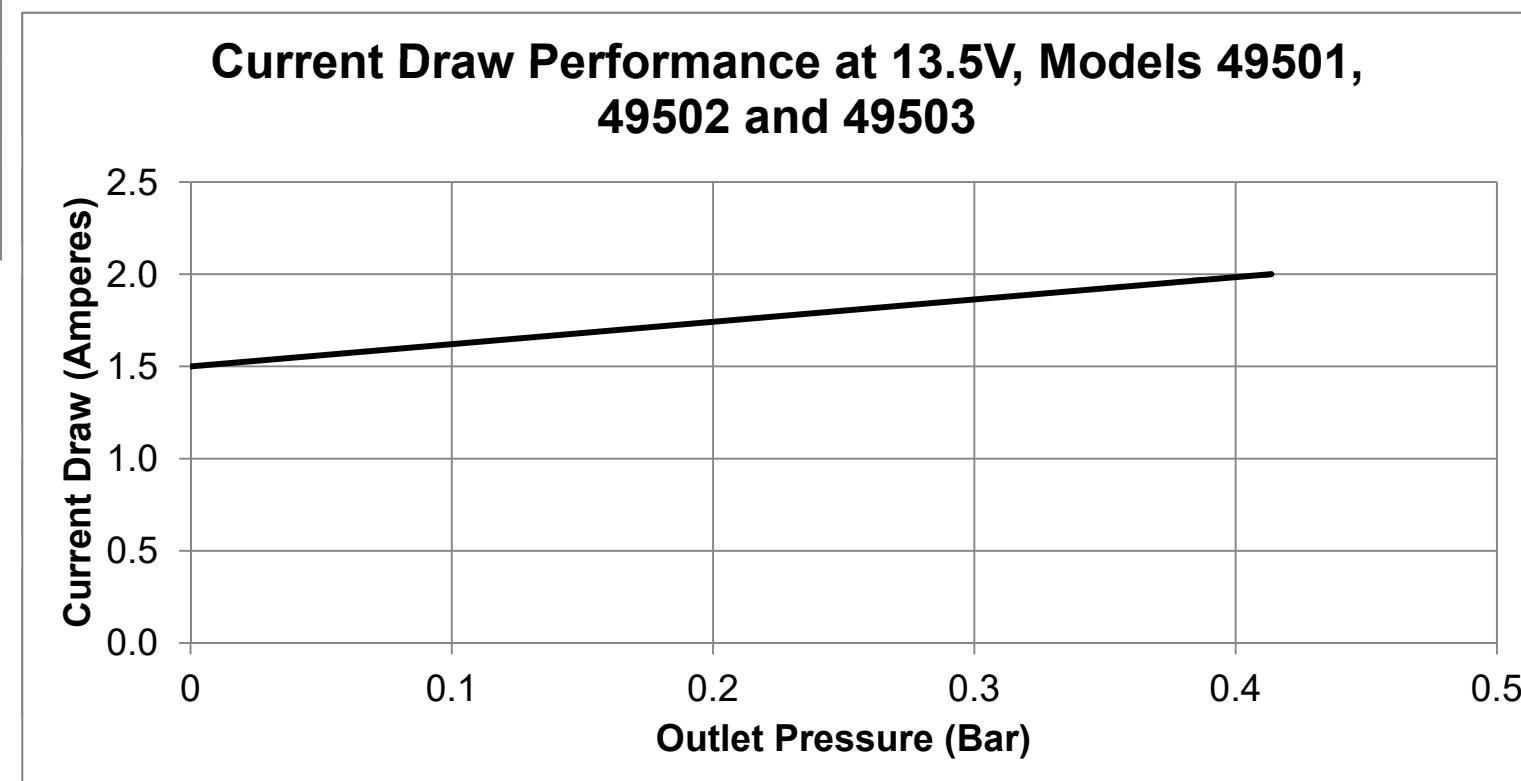
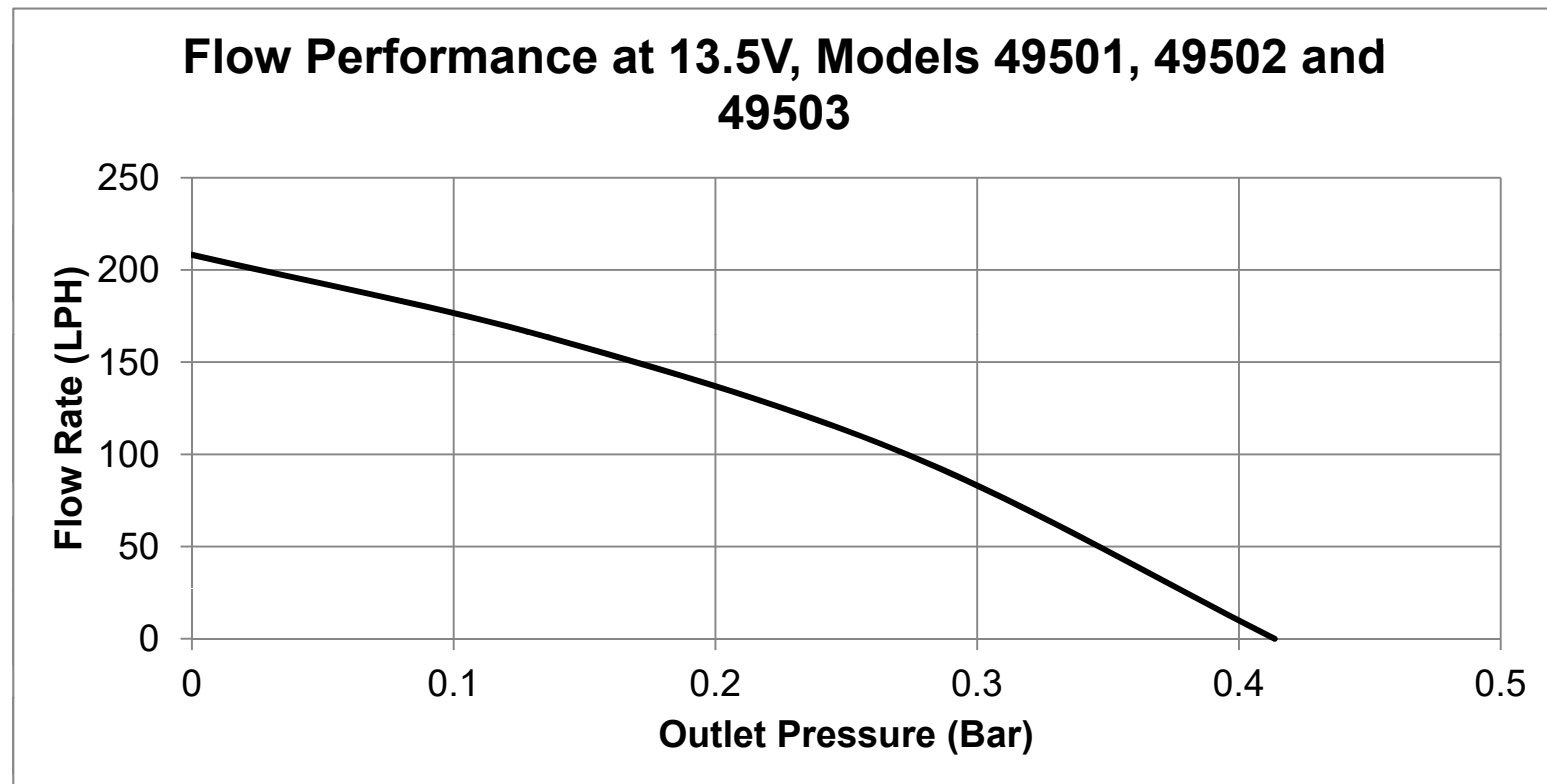

UNLESS OTHERWISE SPECIFIED:

INTERPRET DWG PER ANSI Y14.5
DIMENSIONS ARE IN INCHES
TOLERANCES:
FRACTIONAL: ±1/64"
ANGULAR: ±1/2°
DECIMALS:
X±1 .XX±03 .XXX±010
SURFACE FINISH ✓ OR BETTER
BREAK ALL SHARP EDGES .010 MAX
REMOVE ALL BURRS

THIRD ANGLE PROJECTION

DO NOT SCALE DRAWING

FUELAB
DIGITAL FUEL DELIVERY
Collinsville, Illinois

TITLE:
**ELECTRIC FUEL PUMP,
495xx SERIES**

SIZE DWG. NO. REV
C 112020200

SCALE: 1/1 WEIGHT: SHEET: 1 OF 1