



Operating and Installation Instructions

CAUTION!

This product is to be installed only by persons knowledgeable in the repair and modification of vehicle fuel systems and general vehicle systems modification. Only a qualified technician or mechanic who is aware of applicable safety procedures should perform the installation of this product.

GASOLINE AND OTHER FUELS ARE FLAMMABLE AND CAN BE EXPLOSIVE!

Perform the installation in a well ventilated location only to minimize the build up of fuel vapors. **NO** open flames, smoking or other sources of ignition are to be present during installation, to prevent fire or explosion that can cause serious injury or death. Grinding, cutting, and drilling must be performed with care to prevent ignition. Draining and removal of all fuel and ventilation of vapors in vehicle and fuel system is recommended when performing such procedures. Proper eye and personal protection is required at all times during installation.

WARNING!

The Vehicle's fuel system may be under pressure! Do not loosen any fuel connections until relieving all fuel system pressure. Consult an applicable service manual for instructions to relieve fuel system pressure safely.

Application:

This Installation Kit is intended to work with Fuelab® Velocity Series 100 Fuel System, Model 30301. Consult instructions included with Fuelab® Velocity Series 100 Fuel System, to complete this set of instructions pertaining to the use of this Installation Kit. This Installation Kit is also intended to be used for replacement of OEM lift pump systems that are originally installed on vehicle. This kit applies to Dodge Cummins® Diesel Vehicles, between and including the years of 2005-2013. If this Kit is not correct, please contact your Fuelab® distributor immediately for replacement or selection of an appropriate Installation Kit.

Product Contents:

Verify the contents of this box, against list of components below and on the next sheet, to ensure that nothing is missing. Contact your Fuelab® distributor immediately for replacement. You may have extra parts left over after installation since Fuelab® has included extra parts for all years of the application described. While this kit is designed for designated vehicles, vehicle manufacturers routinely change production components, even during the same production year. Please contact Fuelab® if the particular vehicle has different descriptions or components that are incompatible as described within these instructions.

ITEM	P/N	Description	Qty
1	FL375	Fuel Line, 3/8" , Superflex	15'
2	853610	10 ORB x 06 MJIC 90°	1
3	PORB86	08 ORB x 06 MJIC adapter, Steel	1
4	PO166	06 FJIC swivel x 3/8" Push-lok®	1
5	POE6	06 FJIC swivel x 3/8" Push-lok® 90°	1
6	M1206	12mm x 06 MJIC adapter w/seal	1
7	QC375	3/8" QC x 3/8 barb, Nylon	1
8	WCL375	3/8 Two Wire Clamp	1
9	CBT6	Cable Ties, Nylon 5"	6
10	EPH17-2	Extended pump harness with fused adapter kit and fuse taps	1
11	ADTK	Partial Draw Tube Kit 1/2", for in-tank only	1
12	CBLW-1	Optional Use Convuluted Wire Covering	11'

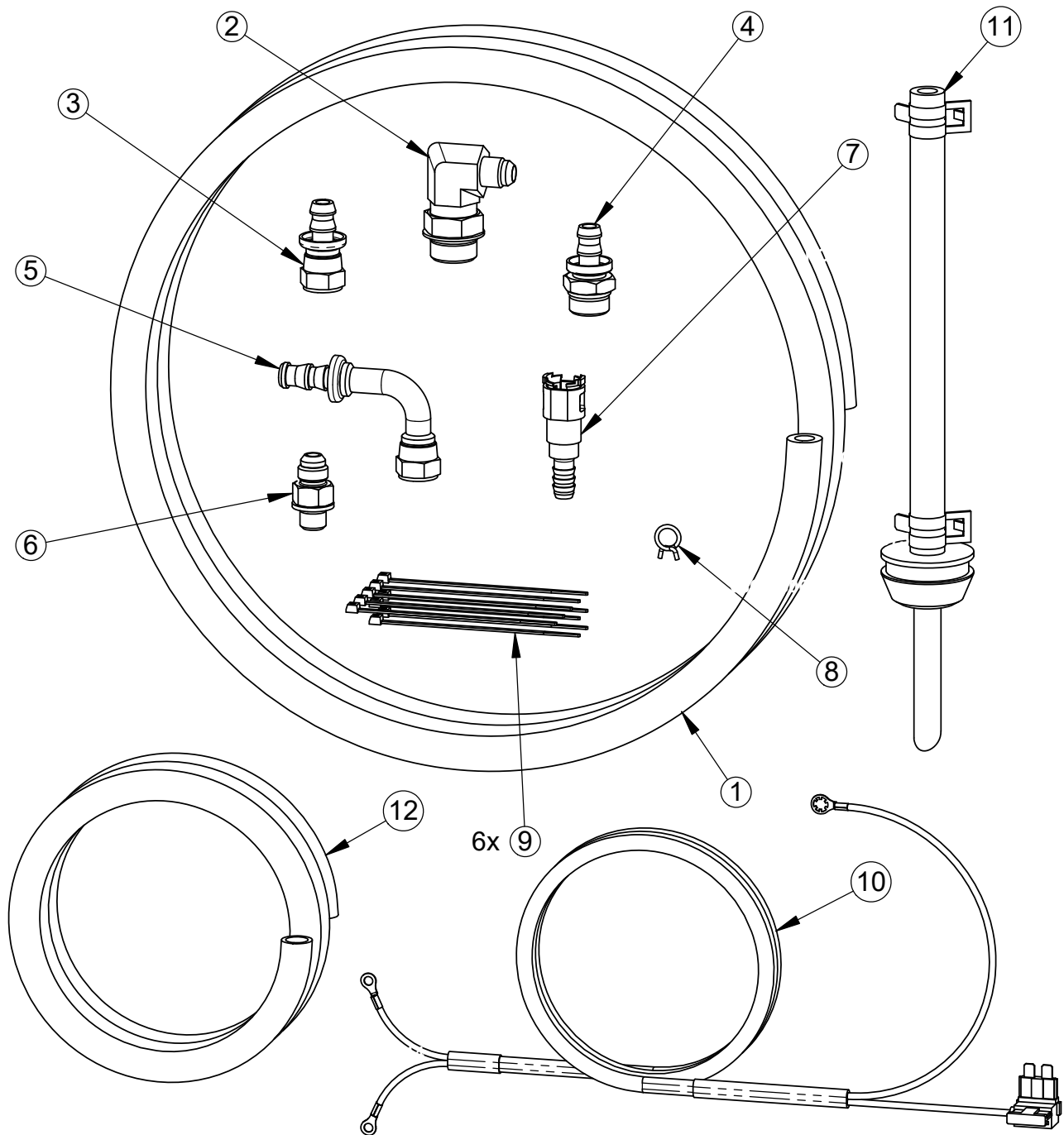

Check above diagram and list shown on previous page, to ensure no components are missing or damaged. Contact your Fuelab® distributor immediately for replacement.

Some items listed in these instructions are included in Lift Pump / Filtration System, sold separately (reference sheet 1, under Application).

FOLLOW ALL INSTRUCTIONS HEREIN AS WELL AS INSTRUCTIONS INCLUDED WITH THE LIFT PUMP / FILTRATION SYSTEM. BOTH SETS OF INSTRUCTIONS CONTAIN IMPORTANT INFORMATION!

The most difficult step of the installation procedure is removing the vehicle's fuel tank. With very little room between the top of the fuel tank and the Bed of the vehicle, it may be difficult to get the fuel lines disconnected. Make sure that the fuel tank is as empty as possible. Even at approximately 1/8th of a tank of fuel, a substantial amount of fuel is still inside. Drain as much as possible! The installation may also be performed with the Bed of the vehicle removed, without the requirement of tank removal. If the tank requires drilling during modification however, the fuel tank **MUST** be removed from the vehicle and completely drained of **ALL FUEL**. For fuel connections using pipe threaded fasteners (tapered threads or non o-ring or flare connections), use Teflon® tape. On connections using Tapered Ends, or Fittings using O-rings, **DO NOT** use Teflon® tape.

In addition to typical professional automotive tools, items you may want to ease the installation, that are not included with this Installation Kit are:

Heat gun or hair dryer and a small amount of oil, to lube the fittings and soften the fuel line for the Push-lok® fittings. Additional items that would be helpful include box cutter or shears for the fuel lines and an air source to blow out all the fittings and hoses. A few extra small to medium size hose clamps can also help (**DO NOT** over-tighten worm gear style clamps) as well as additional Cable Ties.

Step 1: Inventory all of your parts with the included packing list. Lay out the parts to verify that everything is included (see diagram on previous sheet as well as Contents List on the first sheet). Also inventory and lay out all parts of the Lift Pump / Filtration System (sold separately, shown below – Reference Model 30301).

The System Bracket (item S2) attaches to the Lift Pump / Filtration System (item S1) as shown below. Fuelab® recommends attaching the System Bracket to Lift Pump / Filtration System after System Bracket is installed on Front Rail Bracket (item S3, and see next step) for ease of assembly. Dry-fitting your system with rail brackets (explosion view available in companion instructions) is recommended first, to ensure desired bracket adjustment, prior to final assembly.

Make sure to **USE** Loctite® 242 thread adhesive (item S14) on the Captive Studs (items S6) and Acorn Nuts (items S9), prior to final assembly. If the supplied thread adhesive is not used, then unit can vibrate and loosen over time. The thread adhesive is supplied with Lift Pump / Filtration System. Location for Loctite® use during the final assembly is highlighted in the companion instructions (instructions for Model 30301).



Getting to Know the Vehicle

Dodge Cummins Trucks of this era can have several modifications performed to the fuel system. Inherent shortcomings to the original lift pump system have prompted most of these vehicles to be modified. Dealers have typically "upgraded" the fuel systems of these vehicles when in service, particularly when serviced for Injection Pump failure. These failures are generally caused by a fuel supply failure (failure of the lift pump system), that does not provide adequate pressure to protect the Injection Pump. The modification that is typically performed in these cases is to remove the original lift pump and replace it with an adapter fitting (Original Lift Pump is typically attached to the Filter Housing). Additional modifications includes the replacement of the Fuel Module (within the fuel tank) that includes an in-tank fuel pump (the original Module, when an external lift pump is used, has no pump inside). While this modification is an improvement over the original design, aftermarket lift pump systems entered the marketplace to improve upon lift pump performance and filtration capability.

Inspect the vehicle's fuel system against the diagrams to determine the actual fuel system configuration, as this will vary from vehicle to vehicle. Look for a possible aftermarket lift pump and /or filtration system along the frame rails, near the transmission and fuel tank (some of these systems also include blue fuel hose that can help identify the system). Many of these systems can include the addition of one or more filters similar in appearance to the filter used on the Fuelab Model 30301 Fuel System (companion fuel system for this installation kit). Some other modifications to the fuel system can also include the removal of the OEM Filter housing as well as the removal of the OEM Lift Pump. Reference the appropriate diagram below and next sheet, to help determine the vehicle's fuel system configuration.

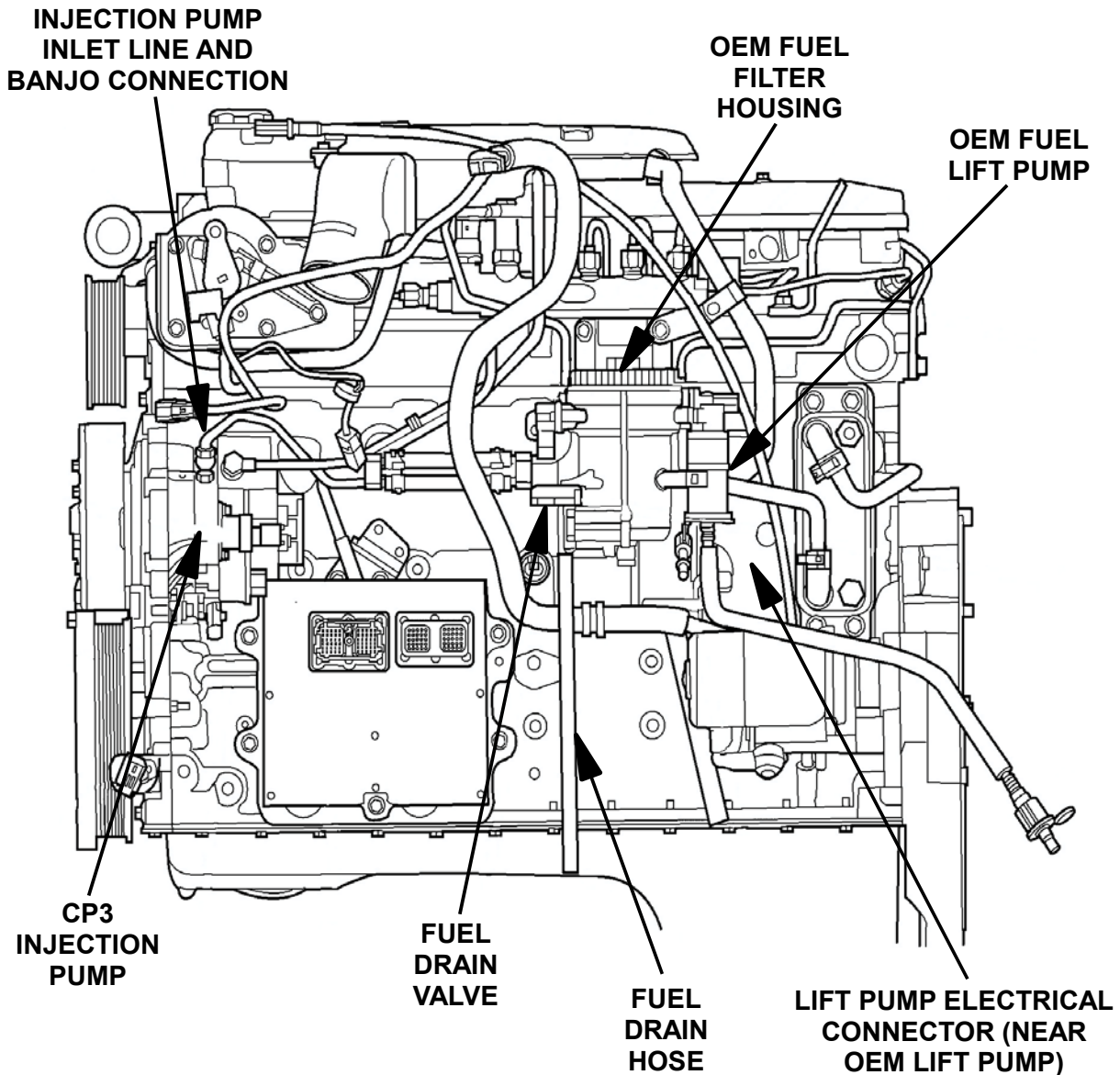

2005-2013 DODGE CUMMINS TRUCKS, USING CP3 INJECTION PUMP

Your vehicle may have other modifications to the fuel system as well. Double check for the correct Injection Pump as well, by comparing the general look of the pump to these included diagrams. Use the following checklist during inspection to understand the vehicle's current fuel system configuration:

- Correct Injection Pump? CP3
- Lift Pump Configuration? External (attached to OEM Filter), External Aftermarket or In-Tank
- Filtration Configuration? OEM Filter Housing, Aftermarket or Both

Installation Options

This installation kit offers an ability to quickly and effectively install a lift pump / filtration system that far exceeds OEM standards in performance and reliability. This installation kit allows the use of the OEM Filter Housing (in addition to the filters supplied with the Fuelab Model 30301 Lift Pump / Filtration System (Sold Separately)). Some vehicle owners have different desires regarding the continued use of the OEM Filter Housing. Keeping the OEM Filter Housing in place has the following advantages:

- Retains OEM Fuel Heater (to improve cold climate performance)
- Retains OEM Water in Fuel (WIF) Sensor
- Retains OEM Fuel Drain
- Redundant Filter
- Faster installation

See the figure (right) labeling key OEM Filter Housing features.

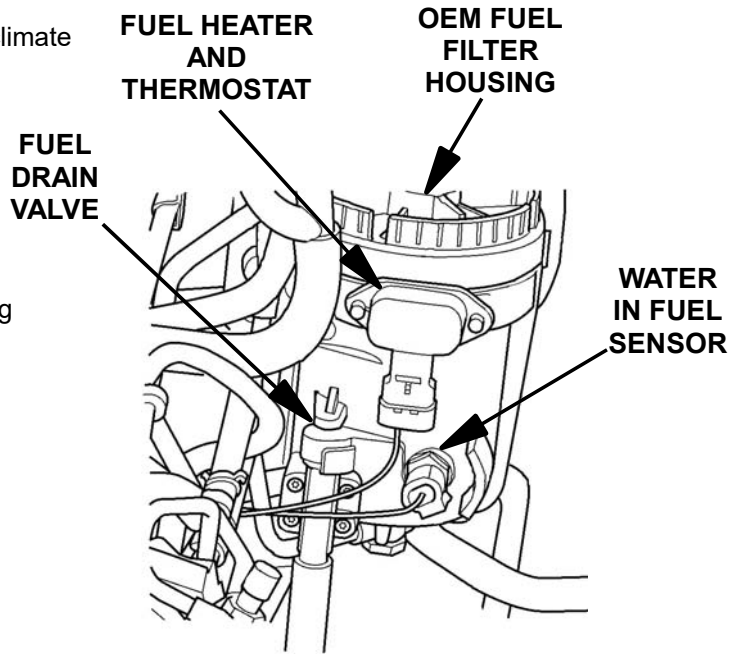

OEM FUEL FILTER HOUSING FEATURES

Step 2: Disconnect the Vehicle's Battery (or batteries, as diesel trucks typically have more than one) by disconnecting the Negative or Ground Terminal(s) of each Battery to disable the Vehicle's Electrical System.

Step 3: Loosely attach the System Bracket (item S2) and bushings (items S7) to the Front Rail Bracket (item S3), using the four (4) Captive Studs (items S6), Stud Washers (items S8) and Acorn Nuts (items S9). Follow the companion instructions for proper assembly orientation. For convenience, the Wiring Harness (item 10) can be attached to the Lift Pump / Filtration System, prior to final installation (reference Step 11, of these instructions). Be sure to note proper wiring polarity, otherwise permanent damage to Lift Pump will result.

Step 4: Find a suitable place to mount the Lift Pump / Filtration System. On a short bed truck, the space is very tight. The Lift Pump / Filtration System normally mounts on the inside of the vehicle's frame.



Placing the Lift Pump / Filtration System into position as a dry-fit (such that the thread adhesive is not being used, and the fasteners are loose) can be helpful, to determine the desired adjustment position of the bracket system as well as determining the desired placement along the vehicle's frame. Multiple height positions are possible by attaching the System Bracket through using the different hardware positions of the Front Rail Bracket. **DO NOT** position to where the Lift Pump / Filtration System can rub against the cab body.



SPECIAL NOTE: Inlet fitting may appear different in photos than the fitting supplied with this kit.

Step 5: If the Bed, Cab or Body of the vehicle is not separated from the vehicle, then proceed with this step for removal of the vehicle's fuel tank. Drain as much fuel as possible from the Fuel Tank. Loosen the hose clamps on the filler tube and the over flow tube to the fuel tank, located on the inside of the fender well. Then loosen the 2 bolts that secure the tank strap until only a few threads are holding it up. Once you have lowered the tank slightly, you must remove the electrical connector and the feed and return fuel lines on top of the tank. For the fuel lines (at disconnects), use a line disconnect tool or a pair of needle nose pliers and squeeze the tabs on either side and pull off the fuel lines from the fuel module (located on top of fuel tank).

Once the tank is lowered, remove the lock ring and remove the fuel tank module from the fuel tank. Use caution not to bend or damage the fuel tank level sender arm and sensor.

With the fuel tank removed, pour or pump out the remaining fuel from the tank before performing modifications. As written in the **CAUTION** section on the first sheet of the instructions, removal of all the fuel is **REQUIRED** if drilling, grinding or cutting is performed on the fuel tank itself, to prevent ignition or fire. Modification of the fuel tank itself is not required, if modification to the fuel tank module is performed only. Removal of all the fuel from the fuel tank module is **REQUIRED**.

Inspect the fuel tank module and its sealing gasket for cracks or damage. Replace components as necessary with OEM replacement components if damaged components are found. Inspect all fuel lines and emission lines as well as line disconnects for extreme brittleness, cracks or damage. Fuel lines must be replaced with fuel compatible hose **ONLY**.

Step 6: Modifying the fuel tank module or fuel tank.

This Installation Kit requires simple modifications to the vehicle's fuel tank module. The procedure includes the removal of the fuel tank module's in-tank fuel pump and subsequent replacement with this kit's Partial Draw Tube Kit (item 11).

Using two or three screw drivers, carefully pry the in-tank pump from its location. Remove the pump and its components attached to it, including the pump's straining filter attached at the bottom of the pump. The original plastic-clear pump supply lines may be cut and removed, as these lines are replaced by the Partial Draw Tube Kit (item 11).

Take care during any prying on the delicate plastic pieces, as these parts may be extremely brittle depending on the age of the vehicle. If the pump mounting components of the fuel module become damage, additional bracketry may have to be fabricated, to install the Partial Draw Tube Kit (item 11).

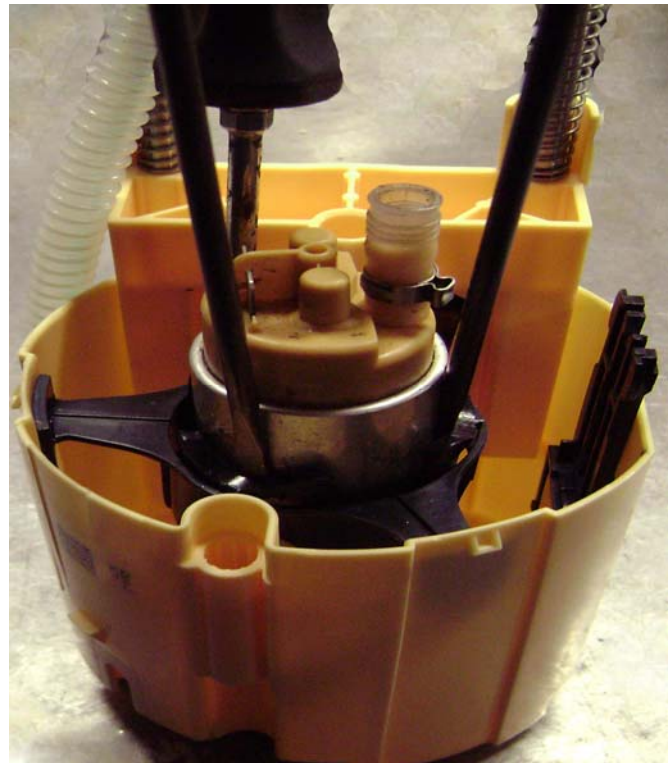

Cut the pump power wires being careful to not cut the fuel level sending unit wires. Be sure that wires are secure and not shorted with each other.

SPECIAL NOTE:

The vehicle's fuel tank module may appear differently than as shown to the left, due to various configurations produced over the various models produced. The Partial Draw Tube Kit installation is considered universal for these OE in-tank fuel pump systems. Secure the Partial Draw Tube Kit using cable ties (not supplied) on Modules not having an in-tank pump.



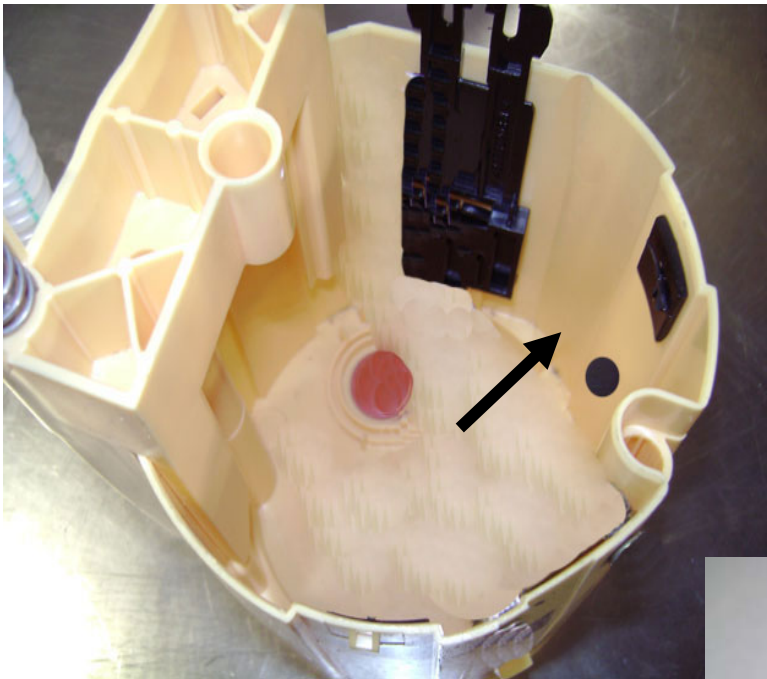

With the pump and screen filter removed, a small orange/red rubber valve can be seen on the bottom of the fuel tank module. Drill an approximately 1/2" hole (see arrow in photo to the left) through the module wall approximately 3" from the bottom. This modification will help keep the module full of fuel.

Remove remaining fuel supply line from the original fuel pump, using a utility knife. Also, carefully remove the original supply hose from the nipple from the underside of the base, of the fuel tank module flange.

Attach the rubber hose portion of the Partial Draw Tube Kit (item 11) to the original supply nipple of the fuel tank module, as shown in the photo to the right. The fuel line from the partial Draw Tube Kit (item 11) may have to be shortened. The fuel module's springs compress upon installation; double check this amount of compression

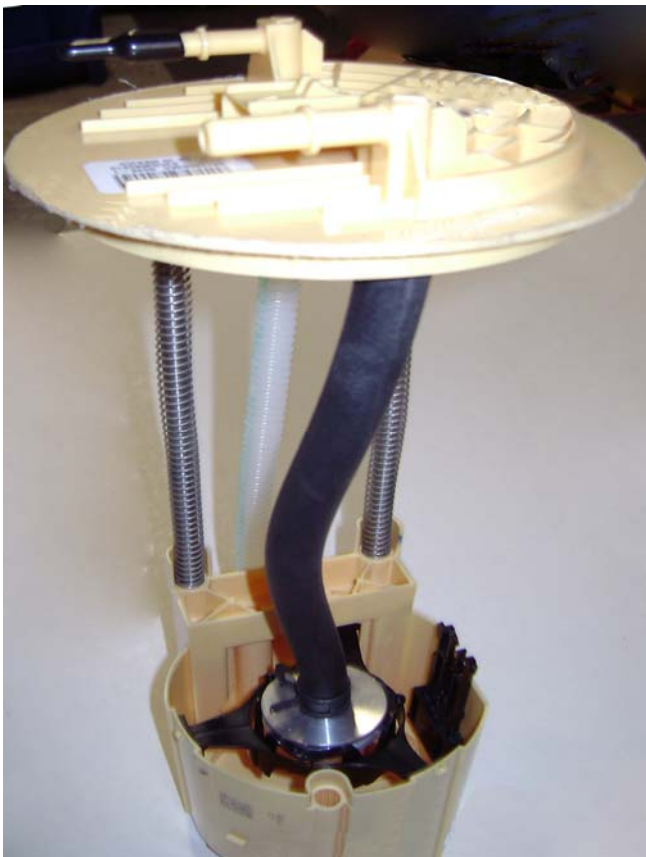

from the fuel module (rough estimate) to ensure that the fuel line does not become kinked.

Install the aluminum portion of the Partial Draw Tube Kit (item 11) into the original fuel pump mount, and push until it locks into place.

Upon completion of modification, the fuel tank module will appear similar to that as shown in the photo to the left.

Install the modified fuel tank module. Take extra care to ensure that the fuel tank level sender arm and sensor do not get damaged upon installation. Before seating the fuel tank module, ensure that the gasket seal is in its proper position prior to setting it in place. Be sure to “clock” the fuel tank module (rotate in orientation) to the original setting.

Re-attach the fuel tank module’s lock ring to secure the fuel tank module back into fuel tank. Position the fuel tank back under the vehicle to begin the process of reinstallation.

Topic: Finding proper Fuse Position, Socket Power Side and Fuse Tap Orientation

This kit uses a Fuse Tap Assembly in the wiring harness, to allow a power tap from the Under-Hood Fuse Box to power the Lift Pump / Filtration System. Possible Fuse Positions (see lid of Fuse Box) for this application include Fuse Numbers (choose one):

9 or 10.

A Test Light or Voltmeter is required to determine the proper orientation of the Fuse Tap. Use the (Positive - Red) probe of the Test Light or Voltmeter to determine the "Power Side" of the Fuse Socket. For the proper leg of the Fuse Tap to be referenced, place probe into one side of the Fuse Socket, while the other Probe (Negative – Black) is placed firmly against a good grounded metal surface. If the probe size is too large, a small straitened paperclip can be used to help establish readings. Check the following conditions before installing the Fuse Tap:

- Check Door or Lid Label for Fuse Block, to verify the correct location of the Fuse (see list above).
- Remove Original Fuse from the Socket, using Fuse Pulling Tool or Needle Nose Pliers.
- With Ignition Key in the "OFF" position, does either side of the Fuse Socket have voltage? If voltage is measured, then look for alternate location, as voltage indicates the wrong operating behavior and therefore is a wrong Fuse Position.
- With Ignition Key in the "ON" position, does either side of the socket have voltage? If no voltage is detected, then re-inspect test equipment and proper Fuse Position. If voltage is measured, then note which side (of the two positions) had measured voltage. This side will be considered to be the "Socket Power Side". When inserting the Fuse Tap, note that the "Power Side" of the Fuse Tap must be inserted into the Socket Power Side to have the proper Fuse Tap Orientation. SPECIAL NOTE: Ignition Key may have to be cycled (OFF-ON-OFF) while observing the Voltmeter or Test Light, as power may be intermittent (depending on the actual circuit being tested).
- Note the Fuse and position of the fuses within the Fuse Tap (bottom fuse is the original fuse removed from the socket, while the "upper" fuse is the fuse for the Lift Pump).

Step 7: Use a lift or secured jack to lift the tank toward the body of the vehicle. Connect the fuel system inlet fuel line (item 1) to the quick connect (item 7). This line attaches directly to the fuel tank module.

Be sure to connect the injection pump overfill as well as emission vent lines and electrical lines. Be sure that all electrical and fuel lines clear between tank and body of the vehicle, such that the fuel lines are not pinched. Reinstall the filler tube as well with corresponding band clamp(s).

Secure the tank, install the mounting straps, and install the mounting strap bolts to complete the reinstallation of the fuel tank.

Step 8: The Fuel Line (item 1) and Push-lok® fittings (items 4, 5 and 9) are very tight. Use a small amount of oil on the fittings and use a heat gun to soften the fuel lines slightly, to fully seat them.

Additional hose clamps (not supplied) at the Push-lok® connection points can be used, however are not necessary.

Connect the Lift Pump / Filtration System's fuel hose as indicated in the directions and run the pressurized supply Fuel Line (item 1) along the frame rail to the injection pump. The Injection Pump Fitting (item 6) and Push-lok® Fitting (item 5) attach directly to the diesel injection pump, allowing the original fuel supply lines, to be removed. Empty the factory fuel filter as may be required, by opening the yellow valve to remove OEM filter.

The Lift Pump / Filtration System has its plumbing ports labeled, as well as these parts are shown in supplied instructions from the Lift Pump / Filtration System. If routed efficiently, approximately 1' or more of fuel line will remain after installation.

Run the fuel supply line (item 1) along the frame rail and up to the injection pump. Use Cable Ties (items 9) or line clamps (not supplied) as necessary; make sure the lines are secured away from the steering shaft.

Step 9: Disconnect the factory fuel supply line and install the Push-lok® fitting, Push-lok® adaptor and fuel supply line.

Step 10: DOUBLE CHECK the fuel lines, to make sure the tank straps are tight, the fill tube and overflow tubes are reconnected.

Step 11: Connect the supplied wiring harness (item 10) to the Lift Pump / Filtration System as described. Connect the black wire to the black negative (-) terminal of Lift Pump. Connect the red wire to the Red (+) terminal of the pump.

SPECIAL NOTE:

Tighten snugly, but do not over tighten the ring terminals with the supplied washers and nuts.

DOUBLE CHECK! Reverse polarity can result in a permanently damaged fuel pump, be sure to correctly attach the harness per the color coded scheme.

Route the wiring harness (item 10) along the driver side frame rail and secure with Cable Ties (items 9). The Wiring Harness's end (electrical connector) gets plugged into the OE lift pump connector. This plug may be identified by tracing the wiring from the fuel module.



Step 12: Connect the power/ground wire to the battery and the bulk of the installation should be complete.

Be sure to fill the fuel tank of the vehicle with at least two gallons of fuel. If fuel system is operating (during starting) but Lift Pump / Filtration System does not build pressure, then additional fuel may be required to add to the fuel tank.

Before the first crank, cycle the key to run 3 times to attempt to prime the Lift Pump / Filtration System. When attempting to start, the engine may operate momentarily and die. This is due to the fuel left in the fuel rail and injection pump. Several attempts may be required to successfully start the engine (driving out initial air in the system). Filling the filter with diesel can make the priming process quicker, in order to start the engine faster.

If you installed correctly you will only see a small part of the bracket and filter showing, **DO NOT** position to where the Lift Pump / Filtration System rubs against the cab body.

Check for leaks after running for five minutes at all connections and pump, if no leaks are found, Road test the vehicle for proper performance.

LIMITED LIFETIME WARRANTY

FUELAB, a division of FCP, Inc., having its principal place of business at **1605 Eastport Plaza Drive, Suite 125, Collinsville, IL 62234, USA** ("Manufacturer") warrants its **FUELAB** products (the "Products") as follows:

1. Limited Lifetime Warranty

Manufacturer warrants that the Products sold hereunder will be free from defects in material and workmanship from the date of purchase for so long as the original purchaser owns the Products. This Limited Lifetime Warranty does not extend to any subsequent owner or transferee of the Products. If the Products do not conform to this Limited Lifetime Warranty during the warranty period (as herein above specified), Buyer shall notify Manufacturer in writing of the claimed defects and demonstrate to Manufacturer's satisfaction that said defects are covered by this Limited Lifetime Warranty. If the defects are properly reported to Manufacturer within the warranty period, and the defects are of such type and nature as to be covered by this Limited Lifetime Warranty, Manufacturer shall, at its option and own expense, furnish replacement Products or replacement parts for the defective Products or refund the purchase price. Removal of Products from vehicle, shipping to Manufacturer and installation of the replacement Products or replacement parts shall be at purchaser's expense. (*Vehicle means any automotive, bike or marine transportation device powered by an internal combustion engine to which the Product is attached. This Product is **NOT** intended or designed for use on aircraft, experimental or otherwise.*)

2. Other Limits

THE FOREGOING IS IN LIEU OF ALL OTHER WARRANTIES, EXPRESS OR IMPLIED, INCLUDING BUT NOT LIMITED TO THE IMPLIED WARRANTIES OF MERCHANTABILITY AND FITNESS FOR A PARTICULAR PURPOSE. This Limited Lifetime Warranty does not cover any damage due to: (a) transportation; (b) storage; (c) improper use; (d) failure to follow instructions for the Products or to perform any preventive maintenance; (e) modification; (f) unauthorized repair; (g) normal wear and tear; or (h) external causes such as accidents, abuse, or other actions beyond Manufacturer's reasonable control. This Limited Lifetime Warranty also does not apply to Products upon which repairs have been effected or attempted by persons other than pursuant to written authorization by Manufacturer. This Limited Lifetime Warranty is not extended if we repair or replace the Products.

3. Exclusive Obligation

THIS LIMITED LIFETIME WARRANTY IS EXCLUSIVE. The sole and exclusive obligation of Manufacturer shall at its option be to repair or replace the defective Products in the manner and for the period provided above or to refund the purchase price. Manufacturer shall not have any other obligation with respect to the Products or any part thereof, whether based on contract, tort, strict liability or otherwise.

4. Other Statements

ORAL OR OTHER WRITTEN STATEMENTS BY MANUFACTURER'S EMPLOYEES, REPRESENTATIVES AND/OR RESELLERS DO NOT CONSTITUTE WARRANTIES, SHALL NOT BE RELIED UPON BY BUYER, AND ARE NOT A PART OF THE CONTRACT FOR SALE OR THIS LIMITED LIFETIME WARRANTY.

5. Entire Obligation

This Limited Lifetime Warranty states the entire obligation of Manufacturer with respect to the Products. If any part of this Limited Lifetime Warranty is determined to be void or illegal, the remainder shall remain in full force and effect.

6. Warranty Service

How Do You Get Service?

If something goes wrong with your Product, contact FUELAB at 618-344-3300, or send an e-mail with proof of purchase to: info@fuelab.com for a Return Authorization Number (RMA). After receiving your RMA send the product postage paid, fully insured, with a brief written description of the problem to:

FUELAB Warranty Department, 1605 Eastport Plaza Drive, Suite 125, Collinsville, IL 62234

We will inspect your Product and contact you within three business days of receipt to give the results of our inspection and an estimate of the labor and/or parts charges required to fix the Product, if applicable. If covered under this Limited Lifetime Warranty, Manufacturer will repair or replace the Product and return it to you at no cost or refund the purchase price. If the Product is NOT covered under this warranty and if you authorize repairs, we will return the repaired Product to you COD, or prepaid via credit card, within three business days. If we find no issues with the returned product and it meets all performance specifications, there will be a \$25 charge to cover technician labor and inspection time. Additional return shipping charges will apply. We will return the repaired Product to you COD, or prepaid via credit card, within three business days.

Limitation of Liability

THE REMEDIES DESCRIBED ABOVE ARE YOUR SOLE AND EXCLUSIVE REMEDIES AND OUR ENTIRE LIABILITY FOR ANY BREACH OF THIS LIMITED LIFETIME WARRANTY, OUR LIABILITY SHALL UNDER NO CIRCUMSTANCES EXCEED THE ACTUAL AMOUNT PAID BY YOU FOR THE DEFECTIVE PRODUCT, NOR SHALL WE UNDER ANY CIRCUMSTANCES BE LIABLE FOR ANY CONSEQUENTIAL, INCIDENTAL, SPECIAL OR PUNITIVE DAMAGES OR LOSSES, WHETHER DIRECT OR INDIRECT.

SOME STATES DO NOT ALLOW THE EXCLUSION OR LIMITATION OF INCIDENTAL OR CONSEQUENTIAL DAMAGES, SO THE ABOVE LIMITATION OR EXCLUSION MAY NOT APPLY TO YOU.