

Operating and Installation Instructions

CAUTION!

This product is to be installed only by persons knowledgeable in the repair and modification of vehicle fuel systems and general vehicle systems modification. Only a qualified technician or mechanic who is aware of applicable safety procedures and fabrication skills should perform the installation of this product.

GASOLINE AND OTHER FUELS ARE FLAMMABLE AND CAN BE EXPLOSIVE!

Perform the installation in a well ventilated location only to minimize the build up of fuel vapors. **NO** open flames, smoking or other sources of ignition are to be present during installation, to prevent fire or explosion that can cause serious injury or death. Grinding, cutting, and drilling must be performed with care to prevent ignition. Draining and removal of all fuel and ventilation of vapors in vehicle and fuel system is recommended when performing such procedures. Proper eye and personal protection is required at all times during installation.

WARNING!

The Vehicle's fuel system may be under pressure! Do not loosen any fuel connections until relieving all fuel system pressure. Consult an applicable service manual for instructions to relieve fuel system pressure safely.

This product is intended for racing, off-road, or marine use only. This fuel system component may not be legal for sale or use on emission controlled motor vehicles; consult local, state and national laws.

Product Contents:

Check the diagram and list of components (right) to ensure that no components are missing from box. Contact your Fuelab distributor immediately for replacement.

72001 Features and Performance Ratings:

| | |
|----------------------|--|
| Pump Compatibility | 3 Phase DC Brushless Fuel Pumps <u>ONLY!</u> (without an internal electronic controller) |
| Maximum Current Draw | 20 Amperes |
| Operating Voltage | 8-18 Volts |

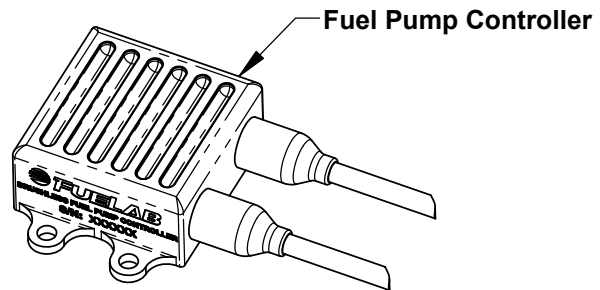

WARNING! This DC Brushless Fuel Pump Controller is **ONLY** compatible with 3 Phase DC Brushless Fuel Pumps without an internal electronic controller. 3 Phase Brushless Fuel Pumps feature three wires that are directly attached to the internal motor's stator windings. This controller is **INCOMPATIBLE** with **ANY** two-wire systems.

Before Installation, Plan Entire Fuel System:

A complete design plan of the entire fuel system must be created for the specific application. These instructions are a guide to help design this plan with respects to integrating this model of external fuel pump controller only. Consult other sources of information and manufacturers instructions for the various components of the fuel system. These instructions are limited to general topics of Fuel Pump Controller installation and may not include specific information pertaining to your specific application. Visit our company website (www.fuelab.com) for specific details pertaining to example fuel systems and other solution ideas. Additional information including advanced troubleshooting, any special alerts and FAQ's pertaining to this and other products is also available. A good design plan for the fuel system must contain consideration for: Pressure and flow rate through various components, quality of components, operating environment (temperature, vibration, shock, general exposure to elements) and local area laws. Begin installation of External DC Brushless Fuel Pump Controller only after a complete plan is established to help avoid fuel system component failure, costly rework, and excessive installation time.

Electrical Planning Notes:

Reference below, for schematic wiring diagram example. Use electrical components as described including electrical connectors that are appropriate for the operating environment of the fuel system, whether its use in street, racing, or marine applications. Electrical connectors for the power leads must be capable of high current draw, note all connections, wire and component rating requirements herein. Solder and use shrink wrap for wire splices for extra reliability. Main wiring schematic diagram below shows the control of relay by ignition switch. This source can be changed as described, or by a toggle switch. Some forms of racing have specific rules regarding electrical switching of fuel system. Consult appropriate racing guidelines, rules and regulations.

MAIN WIRING SCHEMATIC DIAGRAM: (Electrical components shown are not supplied with controller)

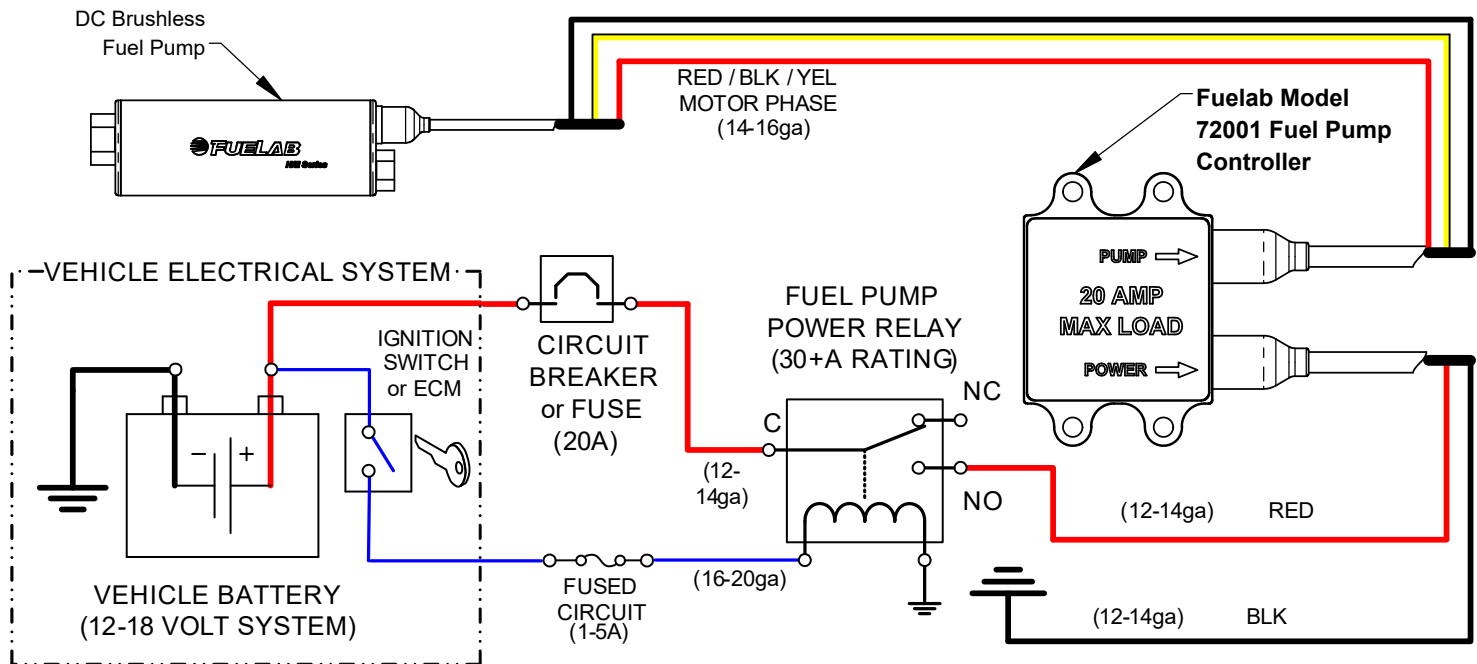

Installation Steps:

1. Disconnect the ground terminal from battery and allow the vehicle's engine and exhaust system to cool. Relieve fuel system pressure per applicable service manual. Follow all Warnings, Cautions and Instructions written on previous pages of these instructions.
2. Modify, remove or replace other fuel system components as required per established build plan (reference notes on previous pages and above).
3. Use the base of the Controller as a drilling template to mark holes for mounting. Choose a location that minimizes exposure to road hazards and debris, away from engine exhaust pipes, near Fuel Pump (to minimize length of motor phase wiring). Use high quality mounting hardware (not supplied) to mount Controller to the vehicle securely. **SPECIAL NOTE: DO NOT** mount Controller within fuel cell or fuel tank! Use only sealed bulkhead connectors to feed wiring for in-tank applications such as use of Fuelab Model 74101 Feedthru.
4. Inspect fuel system for any contact of fuel lines or wires with other components that can cause chafing or rubbing. Secure all components and fuel lines. Ensure that moving components of vehicle are clear. Minimize the distance between the Fuel Pump Controller and the Fuel Pump. Excessive lengths of motor phase wiring can lead to permanent Controller Damage. **SPECIAL NOTE:** Final connections for fuel pump wiring (three motor phase wires) may require verification for proper direction to ensure correct direction of fuel flow. If fuel pump is operating in the reverse direction, swap two of the three phase (Pump) wiring with each other (any two of the three wires). This action reverses the motor and pumping direction. **DO NOT** reverse incoming power polarity (exchanging the Red "+" wire with the Black "-" wire). Reverse polarity for the incoming electrical power to the controller **WILL** result in permanent damage, preventing operation.
5. Connect the vehicle's battery. Perform initial priming (and verification of correct pumping direction): This action can be accomplished by removing fuel line from fuel rail (downstream of fuel pump and filter), allowing the fuel line to empty fluid into fuel safe container. Operate fuel system until fuel exits fuel line. If fuel does not exit fuel line or if a partial vacuum is experienced at the end of the fuel line, then consult Note 3 herein to reverse the motor phase wiring to correct pumping direction. Repeat priming operation as required. Attach fuel line back to the fuel rail after priming fuel system. After tightening connection, verify leak-free operation while checking fuel rail pressure. If fuel pressure is not high enough, repeat priming procedure to ensure that fuel system is properly purged of air. Turn on fuel system (typically by bypassing fuel pump relay) without engine operating. ECU or engine management computer may be controlling the relay. The ECU may only operate fuel system for

a few seconds each time ignition switch is set to on. The fuel system will have to operate several seconds (30+) to prime and drive air out of the fuel system. Inspect vehicle for any leaks. Turn off fuel system and repair any leaks that may be present before continuing.

6. Follow other component installation instructions or other applicable service manuals to perform all applicable inspections and determinations for an adequately operating fuel system.

Fuel System Maintenance Notes:

Periodic inspection and general maintenance is required for longevity and reliability of the fuel system. This action directly affects the fuel pump's performance and reliability. Included with that are periodic inspection and/or filter element replacement. Straining Filters (upstream of Fuel Pump as well as internal straining filters) should be checked and cleaned at least every 50,000 miles (more often for off-road operating conditions). Replace or clean downstream filters (after Fuel Pump) every year or 15,000 miles (more often for off-road operating conditions). Dirty fuel filters can block flow and adversely affect fuel system performance as well as can directly damage the Fuel Pump and Fuel Pump Controller.

Special alert for E85 or Methanol Users: **DO NOT** use cellulose (paper) based filter elements! Water can contaminate the fuel and break down the element, creating debris that can damage injectors and Fuel Pump.

Troubleshooting Notes:

| Problem (Symptom) | Possible Causes | Possible Solutions |
|--------------------------------------|--|---|
| Not operating. | <ul style="list-style-type: none"> • Faulty fuel pump relay. • Faulty, dirty or corroded electrical connections or improperly sized wire. • Faulty, dirty or corroded electrical connections or improperly sized wiring between Controller and Fuel Pump. | Check voltage to Fuel Surge Tank, at power terminals. If voltage is steady and consistent (within 1/2 Volt of battery) then contact Fuelab for assistance or repair. If voltage is inconsistent as described, repair or replace electrical components as required. |
| Not building up fuel pressure. | <ul style="list-style-type: none"> • Incorrect fuel system initial priming procedure. • Improperly mounted Fuel Pump or low fuel level. • Fuel Pump may be operating in reverse direction. | Repeat procedure for proper priming, check fuel level as well as Controller voltage. Consult Installation Step 5, herein. If verified that pump operation may be reversed, consult "Fuel Pump operating in reverse flow" on next line of these Troubleshooting Notes. |
| Fuel Pump operating in reverse flow. | <ul style="list-style-type: none"> • Incorrect order for 3 phase pump / motor wiring. | Switch two of the three pump / motor output wires with each other. Consult Installation Step 4, herein and recheck fuel flow per Installation Step 5, herein. |

Please do not return this product to your retailer. If you experience any performance, reliability or problems during installation or use of this product, please contact Fuelab immediately!

For more tips, advice or troubleshooting please visit our website at www.fuelab.com, e-mail message to info@fuelab.com or call our tech department at 618-344-3300 between 8am and 5pm Central Standard Time.

LIMITED LIFETIME WARRANTY

FUELAB, a division of FCP, Inc., having its principal place of business at **1605 Eastport Plaza Drive, Suite 125, Collinsville, IL 62234, USA** ("Manufacturer") warrants its **FUELAB** products (the "Products") as follows:

1. Limited Lifetime Warranty

Manufacturer warrants that the Products sold hereunder will be free from defects in material and workmanship from the date of purchase for so long as the original purchaser owns the Products. This Limited Lifetime Warranty does not extend to any subsequent owner or transferee of the Products. If the Products do not conform to this Limited Lifetime Warranty during the warranty period (as herein above specified), Buyer shall notify Manufacturer in writing of the claimed defects and demonstrate to Manufacturer's satisfaction that said defects are covered by this Limited Lifetime Warranty. If the defects are properly reported to Manufacturer within the warranty period, and the defects are of such type and nature as to be covered by this Limited Lifetime Warranty, Manufacturer shall, at its option and own expense, furnish replacement Products or replacement parts for the defective Products or refund the purchase price. Removal of Products from vehicle, shipping to Manufacturer and installation of the replacement Products or replacement parts shall be at purchaser's expense. (*Vehicle means any automotive, bike or marine transportation device powered by an internal combustion engine to which the Product is attached. This Product is **NOT** intended or designed for use on aircraft, experimental or otherwise.*)

2. Other Limits

THE FOREGOING IS IN LIEU OF ALL OTHER WARRANTIES, EXPRESS OR IMPLIED, INCLUDING BUT NOT LIMITED TO THE IMPLIED WARRANTIES OF MERCHANTABILITY AND FITNESS FOR A PARTICULAR PURPOSE. This Limited Lifetime Warranty does not cover any damage due to: (a) transportation; (b) storage; (c) improper use; (d) failure to follow instructions for the Products or to perform any preventive maintenance; (e) modification; (f) unauthorized repair; (g) normal wear and tear; or (h) external causes such as accidents, abuse, or other actions beyond Manufacturer's reasonable control. This Limited Lifetime Warranty also does not apply to Products upon which repairs have been effected or attempted by persons other than pursuant to written authorization by Manufacturer. This Limited Lifetime Warranty is not extended if we repair or replace the Products.

3. Exclusive Obligation

THIS LIMITED LIFETIME WARRANTY IS EXCLUSIVE. The sole and exclusive obligation of Manufacturer shall at its option be to repair or replace the defective Products in the manner and for the period provided above or to refund the purchase price. Manufacturer shall not have any other obligation with respect to the Products or any part thereof, whether based on contract, tort, strict liability or otherwise.

4. Other Statements

ORAL OR OTHER WRITTEN STATEMENTS BY MANUFACTURER'S EMPLOYEES, REPRESENTATIVES AND/OR RESELLERS DO NOT CONSTITUTE WARRANTIES, SHALL NOT BE RELIED UPON BY BUYER, AND ARE NOT A PART OF THE CONTRACT FOR SALE OR THIS LIMITED LIFETIME WARRANTY.

5. Entire Obligation

This Limited Lifetime Warranty states the entire obligation of Manufacturer with respect to the Products. If any part of this Limited Lifetime Warranty is determined to be void or illegal, the remainder shall remain in full force and effect.

6. Warranty Service

How Do You Get Service?

If something goes wrong with your Product, contact FUELAB at 618-344-3300, or send an e-mail with proof of purchase to: info@fuelab.com for a Return Authorization Number (RMA). After receiving your RMA send the product postage paid, fully insured, with a brief written description of the problem to:

FUELAB Warranty Department, 1605 Eastport Plaza Drive, Suite 125, Collinsville, IL 62234

We will inspect your Product and contact you within three business days of receipt to give the results of our inspection and an estimate of the labor and/or parts charges required to fix the Product, if applicable. If covered under this Limited Lifetime Warranty, Manufacturer will repair or replace the Product and return it to you at no cost or refund the purchase price. If the Product is NOT covered under this warranty and if you authorize repairs, we will return the repaired Product to you COD, or prepaid via credit card, within three business days. If we find no issues with the returned product and it meets all performance specifications, there will be a \$25 charge to cover technician labor and inspection time. Additional return shipping charges will apply. We will return the repaired Product to you COD, or prepaid via credit card, within three business days.

Limitation of Liability

THE REMEDIES DESCRIBED ABOVE ARE YOUR SOLE AND EXCLUSIVE REMEDIES AND OUR ENTIRE LIABILITY FOR ANY BREACH OF THIS LIMITED LIFETIME WARRANTY, OUR LIABILITY SHALL UNDER NO CIRCUMSTANCES EXCEED THE ACTUAL AMOUNT PAID BY YOU FOR THE DEFECTIVE PRODUCT, NOR SHALL WE UNDER ANY CIRCUMSTANCES BE LIABLE FOR ANY CONSEQUENTIAL, INCIDENTAL, SPECIAL OR PUNITIVE DAMAGES OR LOSSES, WHETHER DIRECT OR INDIRECT.

SOME STATES DO NOT ALLOW THE EXCLUSION OR LIMITATION OF INCIDENTAL OR CONSEQUENTIAL DAMAGES, SO THE ABOVE LIMITATION OR EXCLUSION MAY NOT APPLY TO YOU.